



elsafe railway signalling systems protection



Overview

The Elsafe *Technical Housing & Termination System* is a simple, cost-effective system for protecting railway electrical and signalling systems from interference and transients. The system consists of two main components:

- Termination Modules – These DIN-Rail and G-Rail compatible modules provide a convenient and reliable means of terminating incoming and outgoing cables.
- Protection Cassettes – Available for a wide range of applications, these modules plug into a termination module, protecting its circuit from noise and electrical transients.

Award Winning Features



- Termination modules simplify cabinet wiring and layout.
- Colour-coded modules help prevent wiring errors.
- Test points for non-disruptive live system monitoring.
- Easily-visible mechanical flags indicate end-of-life.
- Plug-In topology guarantees ease of service & testing.
- IP2X Rated for Safety.
- Queensland Rail, Railcorp, ARTC, MTM Approvals.
- Designed & Manufactured in Australia.

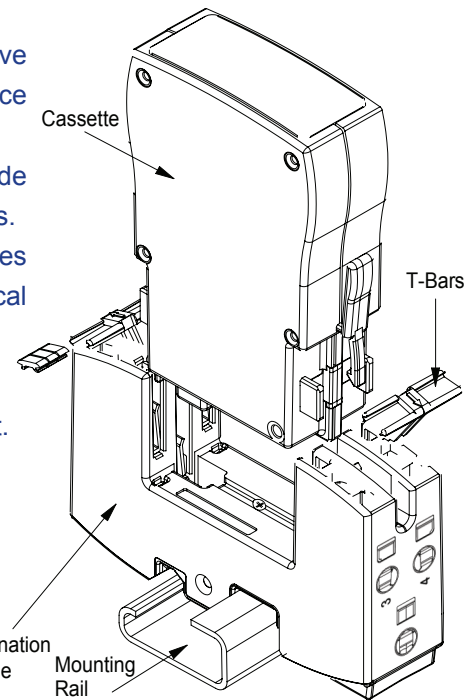

Termination Modules

Termination modules are specially designed to provide a convenient point to terminate both incoming and outgoing cables, as well as accepting a variety of plug-in Protection Cassettes. The modules are designed to attach to either a standard 35 mm top hat DIN or a 32 mm G rail.

Modules feature test sockets for incoming and outgoing cables, which accept standard 4 mm diameter Banana Test plugs.

Termination modules are designed to accept two colour coded T-bars, which are colour-coded to match the coloured front panel of a Protection Cassette, in order to ease identification when the cassette is removed for testing or service.

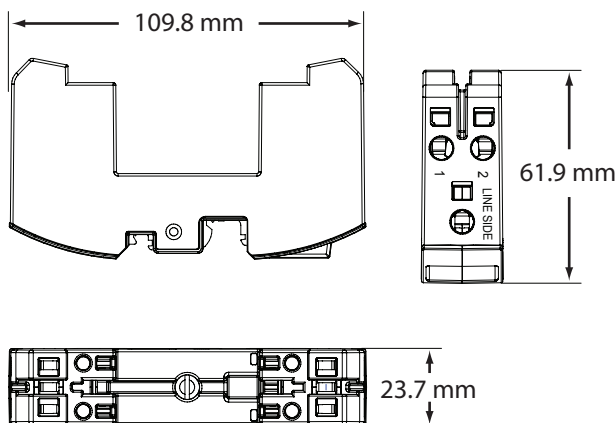

Protection Cassettes

Elsafe's Protection Cassettes can be divided into three broad categories--

- Transient Protection Cassettes – Suppress transient over-voltages caused by, for example, lightning strikes.
- Filter & Transient Protection Cassettes – Provide both transient suppression and noise filtering.
- Speciality Protection Cassettes.

Cassettes are available with a wide range of voltage and current ratings, and have been designed primarily for use in railway signalling systems.

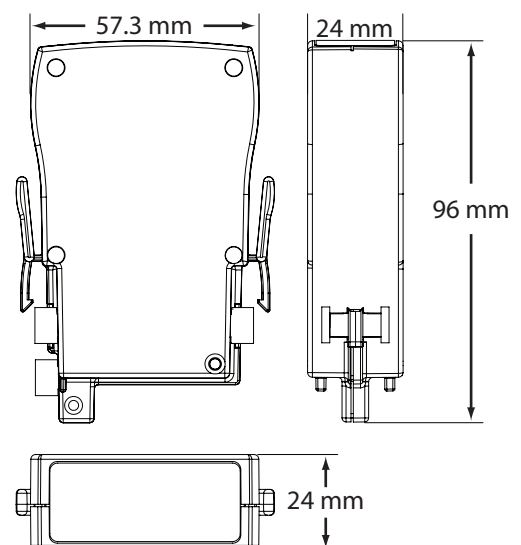

Termination Module Datasheet

Available Variants

Part Number	Description
216600A	General-Purpose Termination Module – Grey
216605A	Termination Module for VZC-series cassettes - Black

Electrical Specifications

Parameter	Value	Units
Maximum Terminal Voltage	750	V ac _{RMS}
Maximum Current	30	A ac _{RMS}
Insulation Breakdown Voltage	6000	V

Mechanical & Environmental Specifications

Termination Module	Elsafe 216600A or 216605A
Dimensions	62mm (D) x 110mm (L) x 24mm (W)
Maximum Cable Size	6 mm ² (Reducing LUG from 16mm ² available)
Terminal Type	Cage Clamp (a registered trade mark of WAGO)
Pull-Out Force	>80N
Operating Temperature	-20°C to + 75°C
Storage Temperature	-20°C to + 85°C
Relative Humidity	Up to 95%
Fire Rating	94 V0
Safety Rating	IP2X (AS 60529-2004, Test Report Available on Request)
Housing Material	Polycarbonate
Drop Test	250mm, any surface
Vibration	Vibration and Shock Proof

Connections

Pin	Shunt Connection	Series Connection	
1	Neutral	Neutral	Line Side
2	Live	Live	
3	N/C	Live	Internal Side
4	N/C	Neutral	

Approvals

Variant	Agency	Approval Number
216600A	Queensland Rail	C0020c
	RailCorp	*11/0804
	Metro Trains Melbourne	MTM-PTA-00036
216605A	Queensland Rail	C0039a

Earthing

Termination modules can be earthed using any of three methods:

- **Bus Bar Locking Screw** - When the termination module is installed on the mounting DIN or G rail, the earth screw is tightened until the points of the bracket penetrate the surface of the mounting rail.
- **Earth Cable** – An earth cable can be connected to the earthing terminal of the termination module.

Protection Cassette Examples

'TPA' Series cassettes feature Gas Discharge Tube (GDT) and Metal Oxide Varistor (MOV) protection, as well as current-limiting resistors. (50Vdc & 110Vac versions available)

'TPB' Series cassettes provide GDT-based protection for high-voltage dc circuits. (200Vdc & 500Vdc versions)

'TPC' Series cassettes feature three-stage protection, incorporating GDTs, MOVs and clamping diodes. They are available for a range of ac and dc voltage ratings. (Versions available between 5.5Vdc and 50Vdc plus 240Vac)

'VZT' Series cassettes feature three (L-N, L-E, N-E) MOVs, providing protection for high-voltage ac circuits. (110Vac, 220Vac & 400Vac versions available)

'VZC' Series cassettes feature a single MOV, connected between Live and Neutral. This series is targeted at high-voltage ac applications. (Versions available between 110Vac and 600Vac)

'TPD' Series cassettes feature three GDTs, and are designed to protect high-voltage dc circuits. Some models have an additional MOV for increased surge current capability. (50Vdc, 100Vdc & 240Vdc versions available)

Filter & Transient Protection Cassettes

'FTA' series cassettes provide both transient protection and low-pass filtering, protecting dc circuits from both surges and high-frequency noise. (40mA & 100mA versions available)

'FTB' series cassettes provide filtering and transient protection to high-voltage ac circuits.

Speciality Protection Cassettes

These cassettes have been designed for certain niche applications, eg: modem / fax transient protector and PSDN isolation transformer.

Cassette Colour Coding Examples

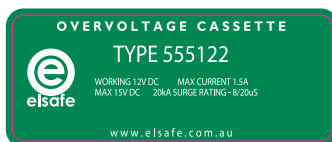

Green 12V DC 555122



Pink 50V DC 555175



Purple 110V AC 216660



Blue 275V AC 555670



Grey 290V DC 216680



Yellow 50V DC 216640



Maroon 480V DC 555690



Brown 700V DC 216690

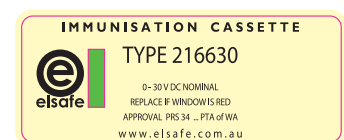

Cream 30V DC 216630

FTA Series – Filter & Transient Protection Cassettes

The FTA Series Filter & Transient Protection Cassettes provides both transient protection and low-pass filtering, protecting DC circuits from both surges and high-frequency noise. The line side is protected by two GDTs, between the inputs and to earth, and the load side by a metal oxide varistor (MOV), with filtering in between. To enhance performance a propriety capacitor has been developed to reduce the let through voltage and to meet the railways failsafe circuitry requirements.

The Cassettes features an indicator window which is normally green, indicating that it is fit for service. Should there ever be a transient that stresses the internal MOV beyond its safe rating the indicator window will turn red. This indicates that the Cassettes have been over stressed and MUST be replaced.

Two Cassettes in the series, 216643 and 216645, have additional self resetting fuses which open up in the case of sustained over current. This is important consideration when using GDT based cassettes in applications where the combination of input power supply and line resistance enables the GDT to continue conducting after an initial transient.

Available Variants

'FTA' Series Part Number	Current Rating	Voltage Rating	Loop Resistance	Cutoff Frequency	Additional Protection
216630	100mA	30V dc	400 Ω	20 Hz	
216640	40mA	50V dc	3 kΩ	2.7 Hz	
216643	40mA	50V dc	3 kΩ	2.7 Hz	300mA Self-Resetting Fuses
216645	40mA	50V dc	3 kΩ	2.7 Hz	1.6 A Self-Resetting Fuses

Line-Side Gas Discharge Tube Specifications

Parameter	Value	Units
DC Spark-Over Voltage	350 ± 15%	V
Impulse Spark-Over Voltage (1KV/μS)	≤900	V
Surge Discharge Current (10/1000μs)	200	A
Surge Discharge Current (8/20μs)	20	kA
AC Discharge Current (@50Hz)	20	A
Insulation Resistance	>10	GΩ
Capacitance (1MHz)	≤1.5	pF
Arc Voltage (@ 1A)	~25	V

Internal-Side Metal Oxide Varistor Specifications

Parameter	Value	Units
Load-Side Metal Oxide Varistor	200 ± 10%	V
Clamping Voltage	340	V
Capacitance	2	nF
Energy (10/1000μs)	140	J
Energy (2ms)	100	J
Peak Current (8/20μs)	10	kA

Mechanical & Environmental Specifications

Termination Module	Elsafe 216600A
Dimensions	62mm (D) x 110mm (L) x 24mm (W)
Operating Temperature	-20°C to + 75°C
Storage Temperature	-40°C to + 85°C
Relative Humidity	Up to 95%
Fire Rating	94 V0
Weight	100g
Housing Material	Polycarbonate

Approvals

Variant	Agency	Approval Number
216630	PTA (WA)	PRS 34
	ARTC	08-08-10-077
	RailCorp NSW	★12/0905
216640	ARTC	08-08-10-077
216643	RailCorp NSW	★12/0301
216645	Queensland Rail	C0024a

Window Labels



FTB Series – Filter & Transient Protection Cassettes

'FTB' series cassettes provide filtering and transient protection for high-voltage AC circuits. The circuit consists of an inductor-capacitor filter, with additional Y capacitors to Earth, for common and differential mode filtering. A Metal Oxide Varistor (MOV) is fitted between live and neutral to minimise the let through voltage. The MOV is in series with a 10A thermal fuse which limits the current during an over voltage event.

A LED shows the status of the cassette and during normal operation it should glow green. If the LED no longer glows this indicates that the cassette has been overstressed and MUST be replaced.

Electrical Specifications

Parameter	555620	555630	Units
Rated Working Voltage	110	240	V ac
Current Rating	15	15	A
Attenuation @ 50KHz	25	25	dB
Attenuation @ 10MHz	80	80	dB

Metal Oxide Varistor Specifications

Parameter	555620	555630	Units
Varistor Clamping Voltage (1mA)	240 ± 10%	430 ± 10%	V
Clamping Voltage (@ 300A peak)	395	710	V
Max Peak Current (8/20 us) – 1 time	6.5	6.5	kA
Max Peak Current (8/20 us) – 2 times	5.0	5.0	kA
Maximum Energy (10/1000 us)	84	115	J
Maximum Energy (2mS)	60	110	J
Typical Capacitance @ 1kHz	830	460	pF

Mechanical & Environmental Specifications

Termination Module	Elsafe 216600A
Dimensions	62mm (D) x 110mm (L) x 24mm (W)
Operating Temperature	-20°C to + 75°C
Storage Temperature	-40°C to + 85°C
Relative Humidity	Up to 95%
Fire Rating	94 V0
Weight	90g
Housing Material	Polycarbonate

Window Labels

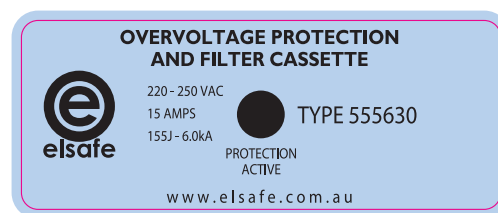
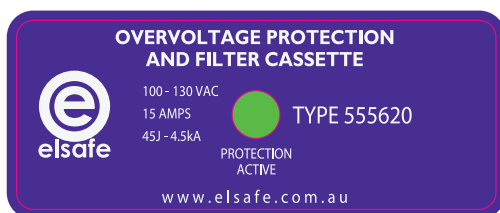

TPA Series - Transient Protection Cassettes

'TPA' Series cassettes feature Gas Discharge Tube (GDT) and Metal Oxide Varistor (MOV) protection, as well as current-limiting resistors, optional self-resetting fuses, and transorb diodes. Please note all cassettes with self-resetting fuses should be derated with temperature according to the graphs on page 2.

The Cassettes feature an indicator window which is normally green, indicating that it is fit for service. Should there ever be a transient that stresses the internal MOV beyond its safe ratings the indicator window will turn red. This indicates that the Cassettes have been overstressed, and MUST be replaced.

Series Part Number	Rated Working Voltage	Nominal Clamping Voltage	Maximum Current (@20°C)	Loop Resistance	Transorb Clamping Voltage	Additional
216651	50V	90V	2A	940mΩ		
216655	50V	90V	1.5A	<1.5Ω		Self-Resetting Fuses
216660	120V	240V	2A	940mΩ		
555175	50V	120V	1.5A	<1.5Ω		Self-Resetting Fuses
555191	50V	91V	1.5A	<1.5Ω	91V	Self Resetting Fuses
555275	50V	120V	2.4A	<0.3Ω		Self Resetting Fuses

Line-Side Gas Discharge Tube Specifications

Parameter	216651 / 216655	216660	555175 / 555191 / 555275	Units
DC Breakdown Voltage	90±15%	350±15%	150±15%	V
Impulse Breakdown Voltage (1kV/μs)	≤650	≤900	≤650	V
AC Discharge Current (50Hz)	20	20	20	A
Surge Discharge Current (10/1000μS)	200	200	200	A
Surge Discharge Current (8/20μS)	20	20	20	kA
Insulation Resistance	>10	>10	>10	GΩ
Capacitance (1MHz)	≤1.5	≤1.5	≤1.5	pF
Arc Voltage at 1A	~15-25	~15-25	~15-25	V

Internal-Side Metal Oxide Varistor Specifications

Parameter	216651 / 216655 / 555175 / 555191	216660	Units
Varistor Voltage (1mA)	120±10%	270±10%	V
Maximum Applied Voltage (AC _{rms})	75	175	V
Maximum Applied Voltage (DC)	100	225	V
Clamping Voltage (100A)	200	455	V
Capacitance	1700	740	pF
Energy (10/1000μs)	40	99	J
Energy (2ms)	30	70	J
Peak Current (8/20μs)	6	6.5	kA

Transorb Diode Specifications

Parameter	555191	Units
Bi-Directional Transorb Breakdown Voltage	91 ± 5%	V
Maximum Clamping Voltage (10/1000µS)	125	V
Maximum Peak Current (10/1000µS)	12	A
Peak Power Dissipation	1500	W
Typical Capacitance @1kHz	1150	pF

Self-Resetting Fuse Specifications

The maximum current rating for cassettes featuring self-resetting fuses must be derated for elevated temperatures, according to the curves below.

Parameter	216655 / 555175 / 555191	555275	Units
Maximum Voltage	60	72	Vdc
Hold Current (@ 20°C)	1600	3750 (derated to 3A ± 20%)	mA
Trip Current	3200	7500	mA
Maximum Current	40	40	A

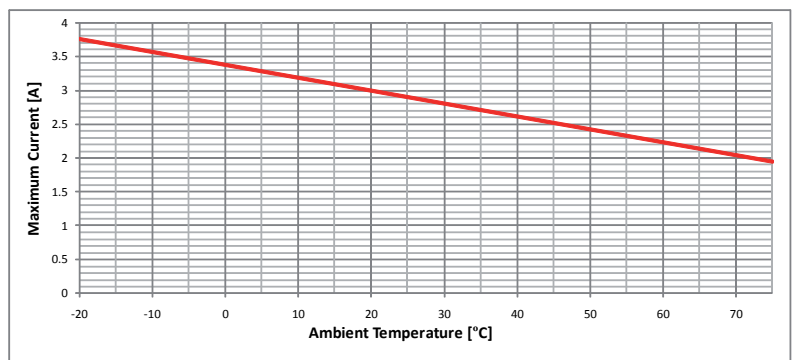
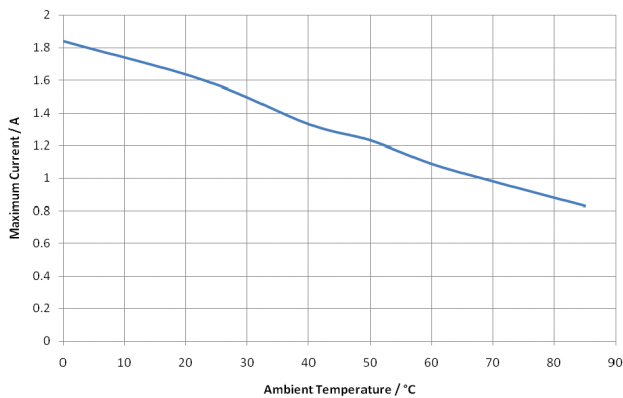

Temperature Derating Graph (LEFT: 216655 / 555175 / 555191, RIGHT : 555275)

*Please note the above graph is the average trip current and may vary up to ± 20%.

Mechanical & Environmental Specifications

Termination Module	Elsafe 216600A
Dimensions	62mm (D) x 110mm (L) x 24mm (W)
Operating Temperature	-20°C to + 75°C
Storage Temperature	-40°C to + 85°C
Relative Humidity	Up to 95%
Fire Rating	94 V0
Weight	100g
Housing Material	Polycarbonate

Approvals

Variant	Agency	Approval Number
216651	Public Transport Authority (WA)	PRS35
216655		
	ARTC	08-08-10-077
216660	Queensland Rail	C0026
	ARTC	08-08-10-077
555175	Queensland Rail	C0040b
555191		

Window Labels

according to the images below



elsafe

Version: OCT 2022

Elsafe, Unit 2, 11-17 Wilmette Place,
 Mona Vale NSW 2103, Australia
 Tel: 1300 357 233 Fax: +61 2 9454 7505
 sales@oelsafe.com.au <https://railways.elsafe.com.au/>

OE House, Calder Park, Thomas Maddison Lane,
 Durkar, Wakefield, WF4 3GH
 Tel: +44 (0) 1924 367255 Fax: +44 (0) 1924 290652
 sales@oelectrics.co.uk <https://oelectrics.co.uk/>



TPB Series - Transient Protection Cassettes

TPB Series cassettes provide transient protection for high-voltage DC circuits. A three-terminal Gas Discharge Tube suppresses excessive voltages between Live or Neutral and Earth.

Available Variants - Electrical Specifications

'TPB' Series Part Number	Nominal Clamping Voltage	Maximum Current – Series Connection	Maximum Current – Shunt Connection	Clamping Voltage Range
216680	290V	30A	200A	230V - 350V
216690	700V	30A	200A	560V - 840V

Gas Discharge Tube Specifications

Parameter	216680	216690	Units
DC Spark-Over Voltage	290 ± 20%	700 ± 20%	V
Impulse Spark-Over Voltage (1KV/μS)	<800	<1200	V
Nominal Impulse Discharge Current (8/20μs)	30	30	kA
Single Impulse Discharge Current (8/20μs)	40	40	kA
Nominal AC Discharge Current	30	30	A
AC Discharge Current (50Hz, 9 Cycles)	50	50	A
Insulation Resistance (250V dc)	>10	>10	GΩ
Capacitance (1MHz)	<20	<20	pF
Arc Voltage at 1A	~25	~25	V

Mechanical & Environmental Specifications

Termination Module	Elsafe 216600A
Dimensions	62mm (D) x 110mm (L) x 24mm (W)
Operating Temperature	-20°C to + 75°C
Storage Temperature	-40°C to + 85°C
Relative Humidity	Up to 95%
Fire Rating	94 V0
Weight	100g
Housing Material	Polycarbonate

Approvals

Variant	Agency	Approval Number
216680	ARTC	08-08-10-077
216690		

Window Labels

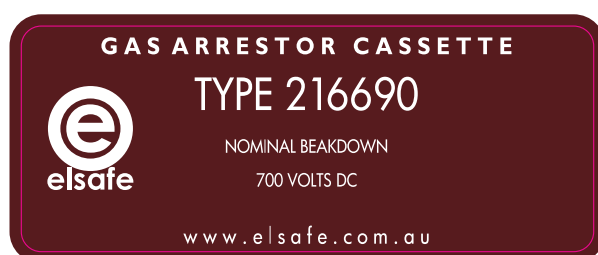
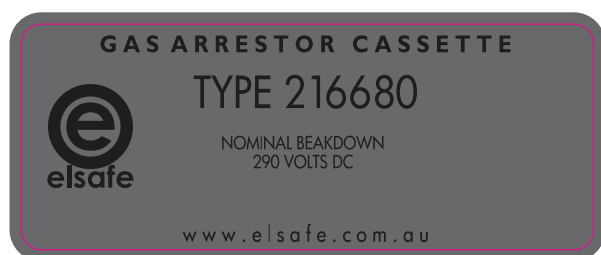

TPD Series – Transient Protection Cassette

The TDP series of Transient protection Cassette features three Gas Discharge Tubes (GDTs), some models (555715, 555718) have an additional Metal Oxide Varistor (MOV) for faster response and to lower the initial let through voltage. The GDTs are connected Live – Neutral, Live - Earth and Neutral - Earth.

Electrical Specifications

Parameters	555710/555715	555718	555720/555725	555730	Units
Nominal Clamping Voltage	90	150	230	350	V
Maximum Current – Series Connection	30	30	30	30	A
Maximum Current – Shunt Connection	200	200	200	200	A
Loop Resistance	<6	<6	<6	<6	mΩ

Gas Discharge Tube Specifications

Parameters	555710/555715	555718	555720/555725	555730	Units
DC Spark – Over Voltage	90 ± 20%	150 ± 20%	230 ± 20%	350 ± 20%	V
Impulse Spark – Over Voltage (1KV/μS)	<700	<700	<800	<800	V
Nominal Impulse Discharge Current (8/20μS)	60	60	60	60	kA
Single Impulse Discharge Current (8/20μS)	80	80	80	80	kA
Nominal AC Discharge Current	60	60	60	60	A
AC Discharge Current (50Hz, 9 Cycles)	100	100	100	100	A
Insulation Resistance (250V dc)	>10	>10	>10	>10	GΩ
Capacitance (1MHz)	<20	<20	<20	<20	pF
Arc Voltage (1A)	~25	~25	~25	~25	V

Metal Oxide Varistor Specifications

Parameter	555715	555718	Units
Varistor Clamping Voltage (1mA)	240	180	V
Clamping Voltage (@300A Peak)	395	300	V
Maximum Peak Current (8/20μS) – 1 Times	6.5	6.5	kA
Maximum Peak Current (8/20μS) – 2 Times	5.0	5.0	kA
Maximum Energy (10/1000 μS)	84	60	J
Typical Capacitance @ 1kHz	830	1100	pF

Mechanical & Environmental Specifications

Termination Module	Elsafe 216600A
Dimensions	62mm (D) x 110mm (L) x 24mm (W)
Operating Temperature	-20°C to + 75°C
Storage Temperature	-40°C to + 85°C
Relative Humidity	Up to 95%
Fire Rating	94 V0
Weight	100g
Housing Material	Polycarbonate

Approvals

Variant	Agency	Approval Number
555710	Queensland Rail	C0049
555715	PTA of WA	PRS38
	ARTC	08-08-10-077
555718	PTA of WA	PRS38
555720	Queensland Rail	C0051
	PTA of WA	PRS37
	ARTC	08-08-10-077
555725		
555730	Queensland Rail	C0051

Window Labels

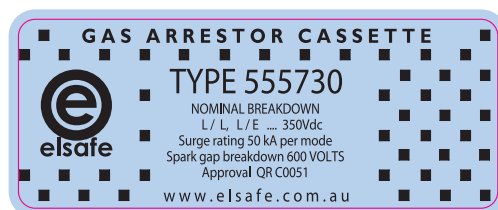
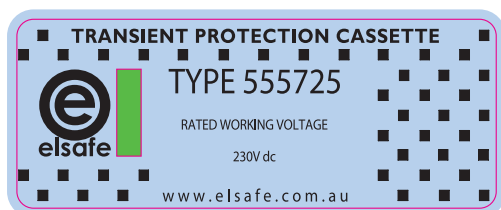
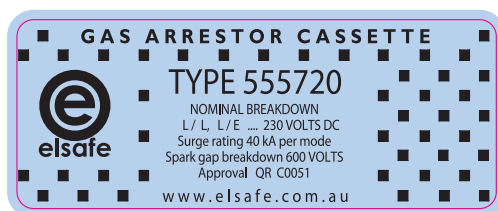
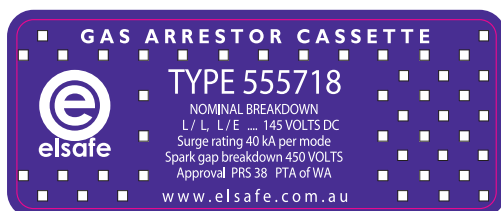
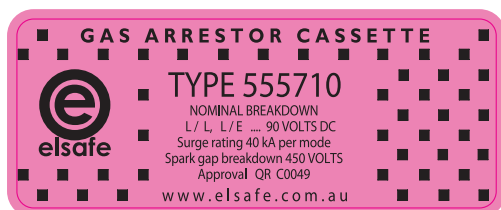

VZC Series – Transient Protection Cassette

The VZC series of Transient Protection Cassettes are fitted with a single MOV, in series with a 35A fuse that is a safety feature that limits the current the MOV may pass during overvoltage events, thus preventing overheating. When combined with an Elsafe 216605A termination module custom protection can be implemented.

The Cassette features an indicator window which is normally green, indicating that it is fit for service. Should there ever be a transient that stresses the internal MOV beyond its safe rating the indicator window will turn red and the MOV will be taken out of circuit. This shows that the Cassettes have been overstressed, and MUST be replaced.

Electrical Specifications

Parameters	555670	555680	555690	555695	555700	Units
Maximum AC Working Voltage	275	150	480	625	750	V _{RMS}
Nominal Clamping Voltage	430	240	780	1000	1200	V
Maximum Current – Series Connection	30	30	30	30	30	A
Maximum Current – Shunt Connection	200	200	200	200	200	A
Loop Resistance	<6	<6	<6	<6	<6	mΩ

Metal Oxide Varistor Specifications

Parameters	555670	555680	555690	555695	555700	Units
Clamping Voltage (1mA)	430 ±10%	240 ±10%	780 ±10%	1000 ±10%	1200 ±10%	V
Clamping Voltage (@300A Peak)	710	395	1290	1650	2000	V
Maximum Peak Current (8/20µS) – 1 Times	40	40	40	40	40	kA
Maximum Peak Current (8/20µS) – 2 Times	30	30	30	30	30	kA
Maximum Energy (10/1000 µS)	550	360	1020	1250	1400	J
Typical Capacitance @ 1kHz	3.2	5.7	1.75	1.36	1.2	nF

Mechanical & Environmental Specifications

Termination Module	Elsafe 216605A
Dimensions	62mm (D) x 110mm (L) x 24mm (W)
Operating Temperature	-20°C to + 75°C
Storage Temperature	-40°C to + 85°C
Relative Humidity	Up to 95%
Fire Rating	94 V0
Weight	90g
Housing Material	Polycarbonate

Wiring Information

A suggested wiring scheme, which protects a circuit from line-to-line and line-to-earth transients, is shown below--

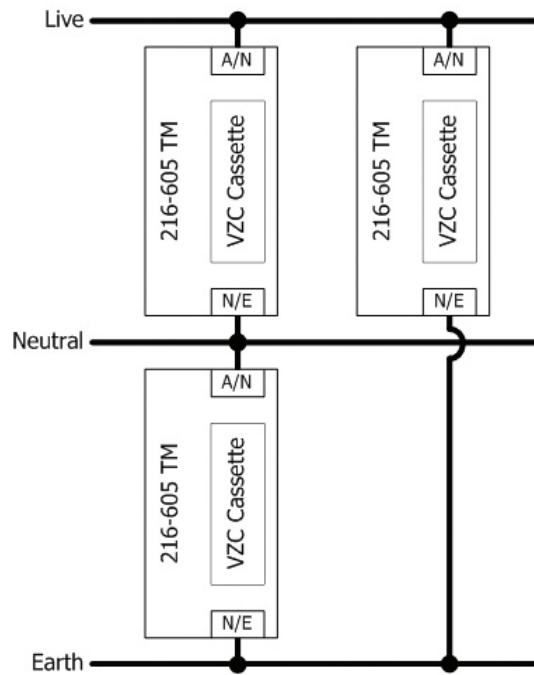

VZC Termination Module

A termination module has been developed specifically for the VZC series cassettes. Connection labels are shown below--

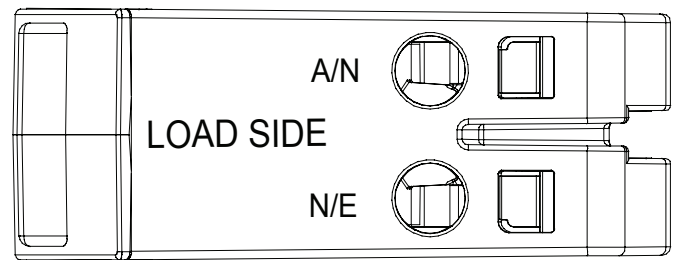
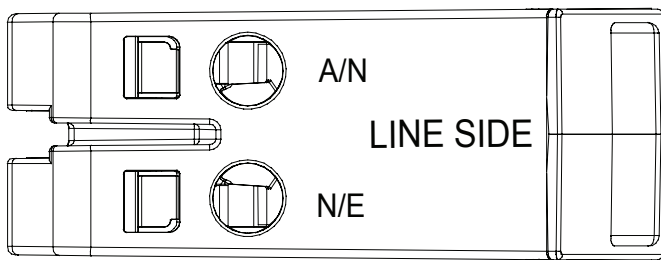

Approvals

Variant	Agency	Approval Number
555670	Queensland Rail	C0041
	ARTC	08-08-10-077
555680	Queensland Rail	C0041
	ARTC	08-08-10-077
555690	Queensland Rail	C0041
	ARTC	08-08-10-077
555695		
555700		

Window Labels

ARRESTOR CASSETTE

TYPE 555670
 VZC 275/40N, 275V 40KA / 550J
 QR CERT C0041, CS4608
 MAX THRU CURRENT 30A
 REPLACE IF WINDOW IS RED

 www.elsafe.com.au

ARRESTOR CASSETTE

TYPE 555680
 VZC 150/40N, 150V 40KA / 360J
 QR CERT C0041, CS4608
 MAX THRU CURRENT 30A
 REPLACE IF WINDOW IS RED

 www.elsafe.com.au

ARRESTOR CASSETTE

TYPE 555690
 VZC 480/25N, 480V 25KA / 550J
 Q RAIL CERT C0041, CS4608
 REPLACE IF WINDOW IS RED

 www.elsafe.com.au

ARRESTOR CASSETTE

TYPE 555695
 VZC 625/40N, 625V 40KA / 1050J
 CS4608
 MAX THRU CURRENT 30A
 REPLACE IF WINDOW IS RED

 www.elsafe.com.au

TRANSIENT PROTECTION CASSETTE

TYPE 555700
 MAXIMUM WORKING VOLTAGE 750Vac
 REPLACE IF WINDOW IS RED

 www.elsafe.com.au

VZT Series – Transient Protection Cassette

The VZT series of Transient Protection Cassettes are fitted with a single Metal Oxide Varistor (MOV) package comprising of three MOVs, designed to suppress Line to Line and Line to Earth, in series with a 35A fuse that is a safety feature that limits the current the MOV may pass during overvoltage events, thus preventing overheating. When combined with an Elsafe 216600A termination module custom protection can be implemented.

The Cassette features an indicator window which is normally green, indicating that it is fit for service. Should there ever be a transient that stresses the MOV in the cassette beyond its safe rating the indicator window will turn red. This indicates that the cassette has been overstressed and MUST be replaced.

Specifications

Parameters	Electrical	555660	555663	555665	Units
AC Rated Working Voltage		275	485	150	V rms
Nominal Clamping Voltage		430	780	240	V
Maximum Current – Series Connection		30	30	30	A
Maximum Current – Shunt Connection		200	200	200	A
Loop Resistance		<6	<6	<6	mΩ

Metal Oxide Varistor Specifications

Parameters	555660	555663	555665	Units
Varistor Clamping Voltage (1mA)	430 ±10%	780 ±10%	240 ± 10%	V
Clamping Voltage (@300A Peak)	710	1290	395	V
Maximum Peak Current (8/20µS) – 1 Times	40	40	40	kA
Maximum Peak Current (8/20µS) – 2 Times	30	30	30	kA
Maximum Energy (10/1000 µS)	500	1020	360	J
Typical Capacitance @ 1kHz	3.2	1.75	5.7	nF

Mechanical & Environmental Specifications

Termination Module	Elsafe 216600A
Dimensions	62mm (D) x 110mm (L) x 24mm (W)
Operating Temperature	-20°C to + 75°C
Storage Temperature	-40°C to + 85°C
Relative Humidity	Up to 95%
Fire Rating	94 V0
Weight	90g
Housing Material	Polycarbonate

Approvals

Cassette	Agency	Approval No
555660		
555663		
555665	Metro Trains Melbourne	MTM-PTA-00036

Window Labels

VZT - OVERVOLTAGE CASSETTE
TYPE 555660



NOMINAL VOLTAGE: 275V AC
 MAX VOLTAGE: 430V
 MAX CURRENT: 30A
 SURGE RATING: 40kA

REPLACE IF WINDOW IS RED www.elsafe.com.au

VZT - OVERVOLTAGE CASSETTE
TYPE 555663



NOMINAL VOLTAGE: 485V AC
 MAX VOLTAGE: 780V
 MAX CURRENT: 30A
 SURGE RATING: 40kA

REPLACE IF WINDOW IS RED www.elsafe.com.au

VZT - OVERVOLTAGE CASSETTE
TYPE 555665



NOMINAL VOLTAGE: 150V AC
 MAX VOLTAGE: 240V
 MAX CURRENT: 30A
 SURGE RATING: 40kA

REPLACE IF WINDOW IS RED www.elsafe.com.au MTM-PTA-00036

216600A / 216605A – Termination Modules Incorporating Cage Clamp Technology

Termination modules are specially designed to provide a quick and convenient point to terminate both incoming and outgoing cables by using CAGE CLAMP Technology (a registered trade mark of WAGO), as well as accepting a variety of plug-in Protection Cassettes. The modules are designed to attach to either a standard 35 mm top hat DIN or a 32 mm G rail.

Vibration and Shock Proof - Fast - Maintenance Free.

Modules feature test sockets for incoming and outgoing cables, which accept standard 4 mm diameter banana test plugs.

IP2X rated for Safety.

Termination modules are designed to accept two colour coded T-bars, which are colour-coded to match the coloured front panel of a Protection Cassette, for easy identification when the cassette is removed for testing or service.

Available Specifications

Part Number	Description
216600A	General Purpose Termination Module – Grey
216605A	Non-Earthed Termination Module for VZC series cassettes - Black

Electrical Specifications

Parameter	Value	Units
Maximum Terminal Voltage	750	V ac _{RMS}
Maximum Current	30	A ac _{RMS}
Insulation Breakdown Voltage	6000	V

Mechanical & Environmental Specifications

Termination Module	Elsafe 216600A or 216605A
Dimensions	62mm (D) x 110mm (L) x 24mm (W)
Maximum Cable Size	6 mm ² (Reducing LUG from 16mm ² available)
Terminal Type	Cage Clamp (a registered trade mark of WAGO)
Pull-Out Force	>80N
Operating Temperature	-20°C to + 75°C
Storage Temperature	-20°C to + 85°C
Relative Humidity	Up to 95%
Fire Rating	94 V0
Safety Rating	IP2X (AS 60529-2004, Test Report Available on Request)
Housing Material	Polycarbonate
Drop Test	250mm, any surface
Vibration	Vibration and Shock Proof

Connections

Pin	Shunt Connection	Series Connection	
1	Neutral	Neutral	Line Side (External)
2	Live	Live	
3	N/C	Live	Internal Side
4	N/C	Neutral	

Approvals

Variant	Agency	Approval Number
216600A	Queensland Rail	C0020c
	RailCorp	*11/0804
	Metro Trains Melbourne	MTM-PTA-00036
216605A	Queensland Rail	C0039a

Earthing

The 216605A termination module has no dedicated earth connection points.
The 216600A termination modules can be earthed using any of two methods:

- Bus Bar Locking Screw** - When the termination module is installed on the mounting DIN or G rail, the earth screw is tightened until the points of the bracket penetrate the surface of the mounting rail.
- Earth Cable** – An earth cable can be connected to the earthing terminal of the termination module.

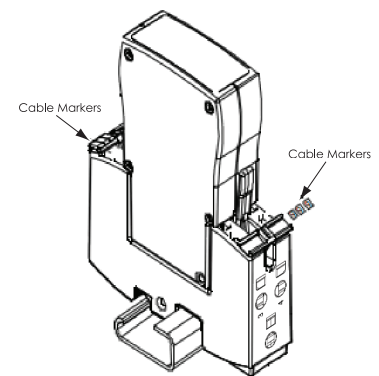
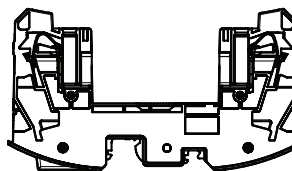
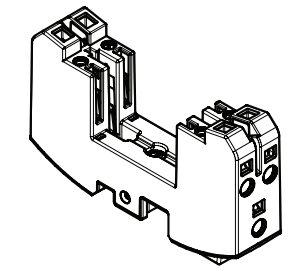
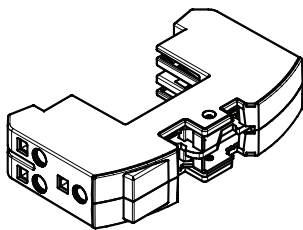
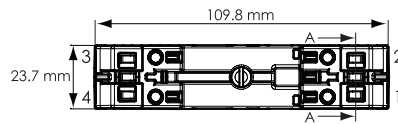
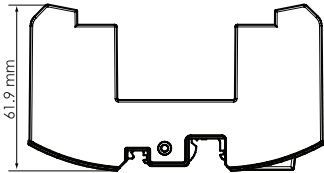

Cassette and Termination Module

741014 – 90° Termination Module Installation Tool

The installation of Termination Modules is now much faster and easier with the aid of the new 90° Termination Module Tool. (Elsafe part number 741014) This tool is used in conjunction with CAGE CLAMP (a registered trade mark of WAGO) technology which is now incorporated into all Elsafe Termination Modules and enables simple installation

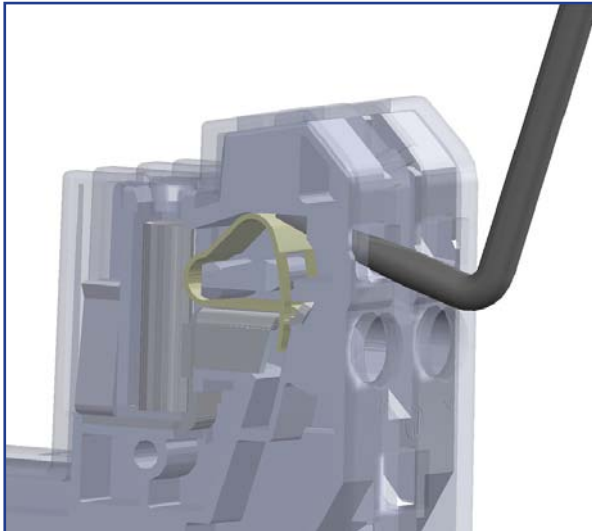

1 Insert the tool

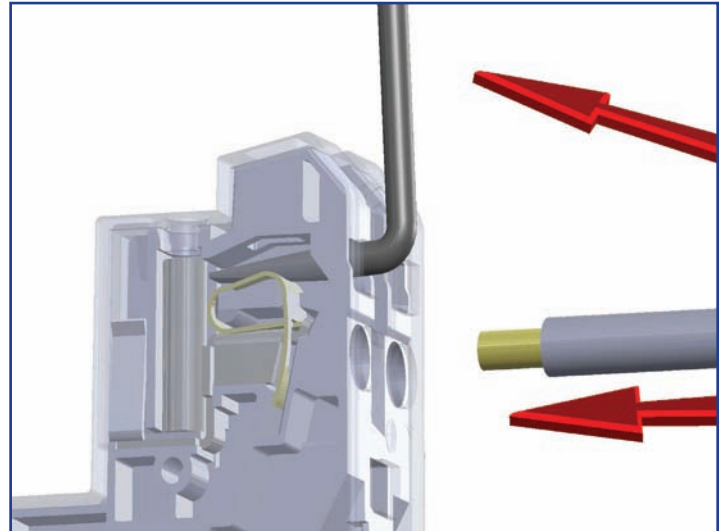

2 Pull the tool towards the direction of the termination module to open the clamp and insert the cable (as per the image above)

Please refer to the Elsafe termination module wiring instructions (document number 606600) for further installation instructions.

This new technology ensures that the redesigned Elsafe termination module is now

- Vibration proof
- Faster to install as no screwing of the terminals is required
- Maintenance free

Labour costs can further be reduced as there is no need to ferrule or pin the stripped wires before installation.

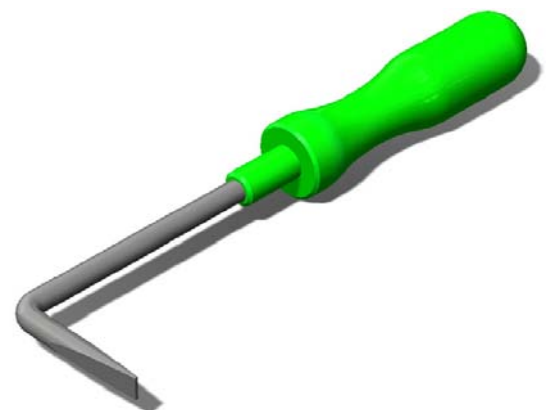
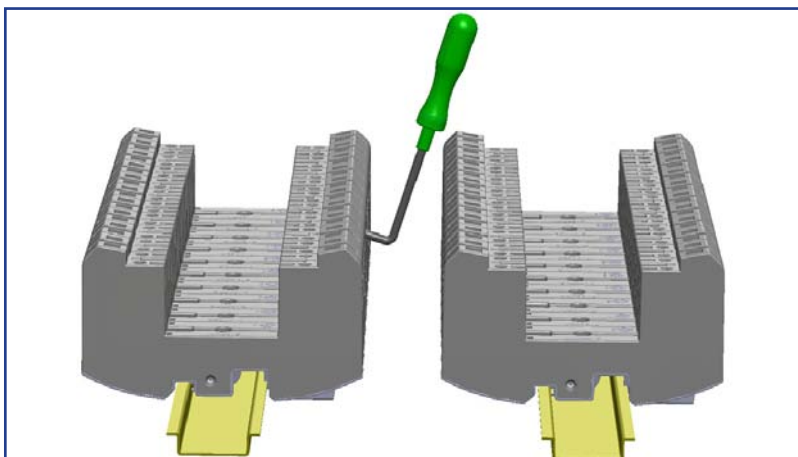

The Elsafe 90° tool also allows for banks of termination modules to be installed close together.

elsafe

Version: OCT 2022

Elsafe, Unit 2, 11-17 Wilmette Place,
Mona Vale NSW 2103, Australia
Tel: 1300 357 233 Fax: +61 2 9454 7505
sales@oeelsafe.com.au <https://railways.elsafe.com.au/>

OE House, Calder Park, Thomas Maddison Lane,
Durkar, Wakefield, WF4 3GH
Tel: +44 (0) 1924 367255 Fax: +44 (0) 1924 290652
sales@oeelectrics.co.uk <https://oeelectrics.co.uk/>



Vibration-proof-fast-maintenance-free!

The Elsafe termination module has been redesigned so that it now incorporates CAGE CLAMP Technology (a registered trade mark of WAGO)

The vibration-proof properties of CAGE CLAMP® connections were tested and verified in a vibration test to IEC/EN 60068-2-6. In this test, a variable frequency band up to 2000 Hz, at different accelerations up to 20 G and different amplitudes up to 20 mm, was passed in three axes. Extremely demanding test requirements for electrical installations in rolling stock (IEC/EN 61373) are prescribed by railway authorities or the testing agencies for marine approvals, such as GL, LR and DNV. These rigorous tests were also passed.

In the impact test to IEC/EN 60068-2-27 or for railway applications to IEC/EN 61373, the test samples were exposed to instant shock stresses, instead of permanent vibrations. Stresses up to 100G on the x, y, and z-axis were passed without any problems.

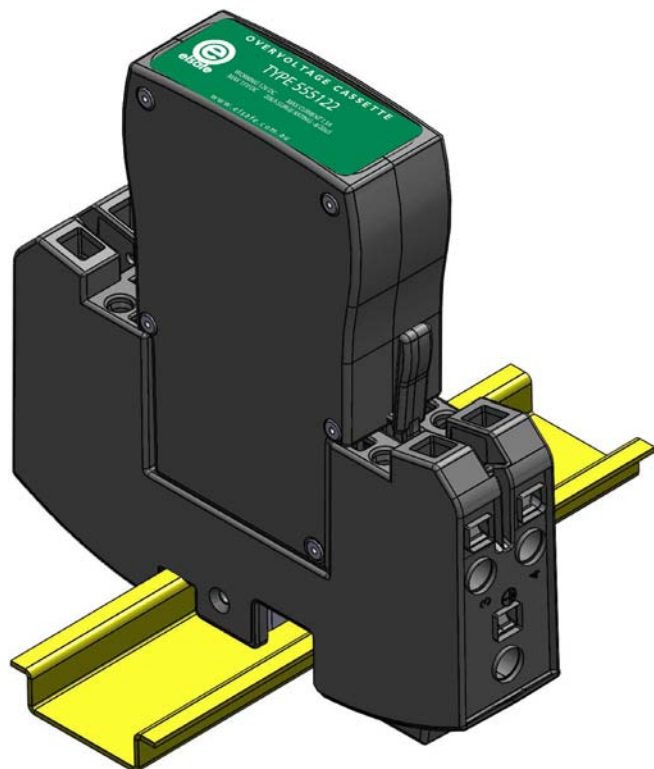
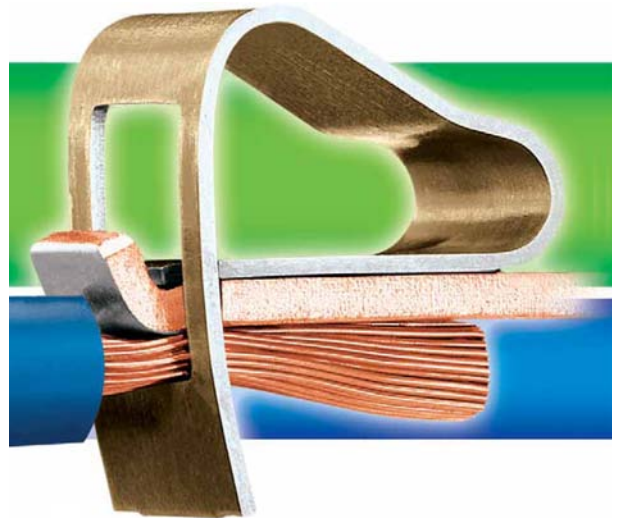

The maintenance-free feature results from the excellent long term consistency of the electrical and mechanical properties of the clamping connection – more accurately, the clamping point. The voltage drop test serves in the evaluation of the clamping point quality under stresses such as vibrations, temperature changes and corrosive influences, in order to verify the gastightness of the contact point. The CAGE CLAMP® technology has proven its long term consistency in laboratory tests by international approval authorities as well as in worldwide applications.

1

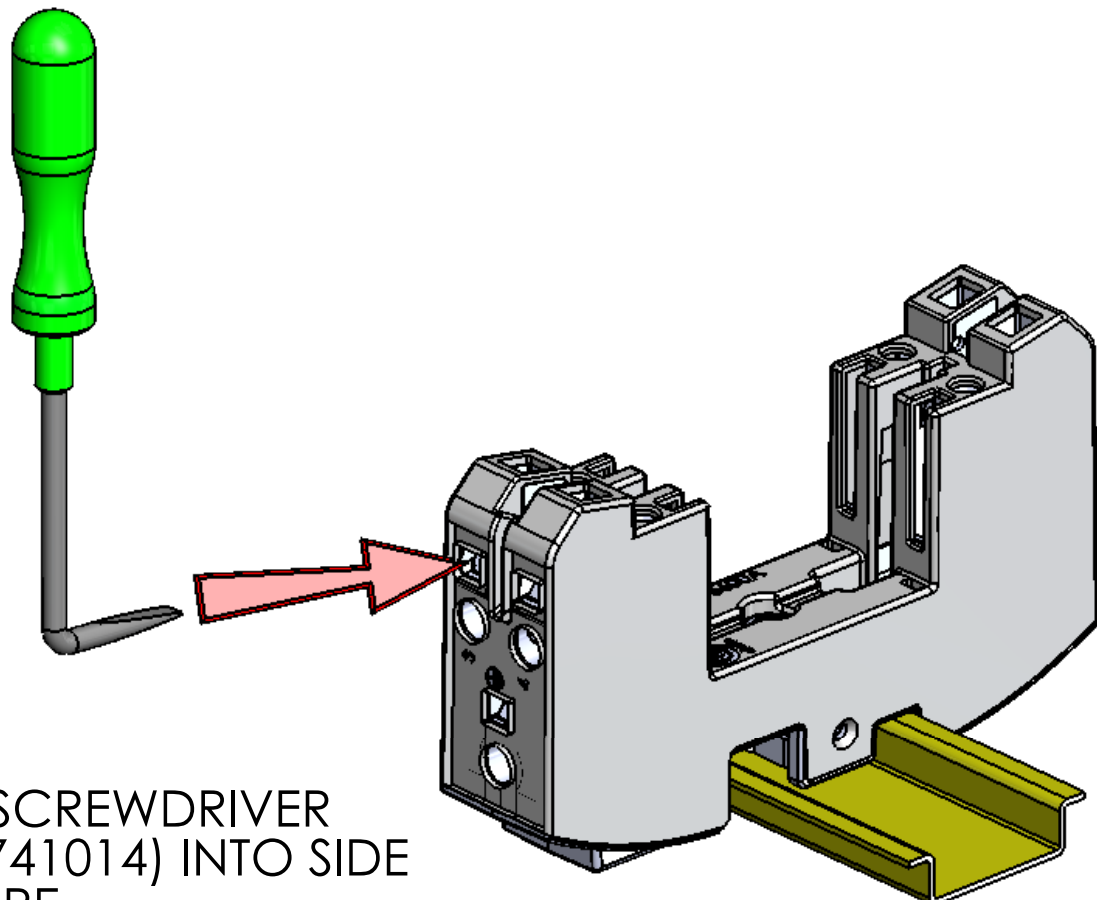

INSERT SPECIAL SCREWDRIVER (PART NUMBER 741014) INTO SIDE RELEASE APERTURE

2

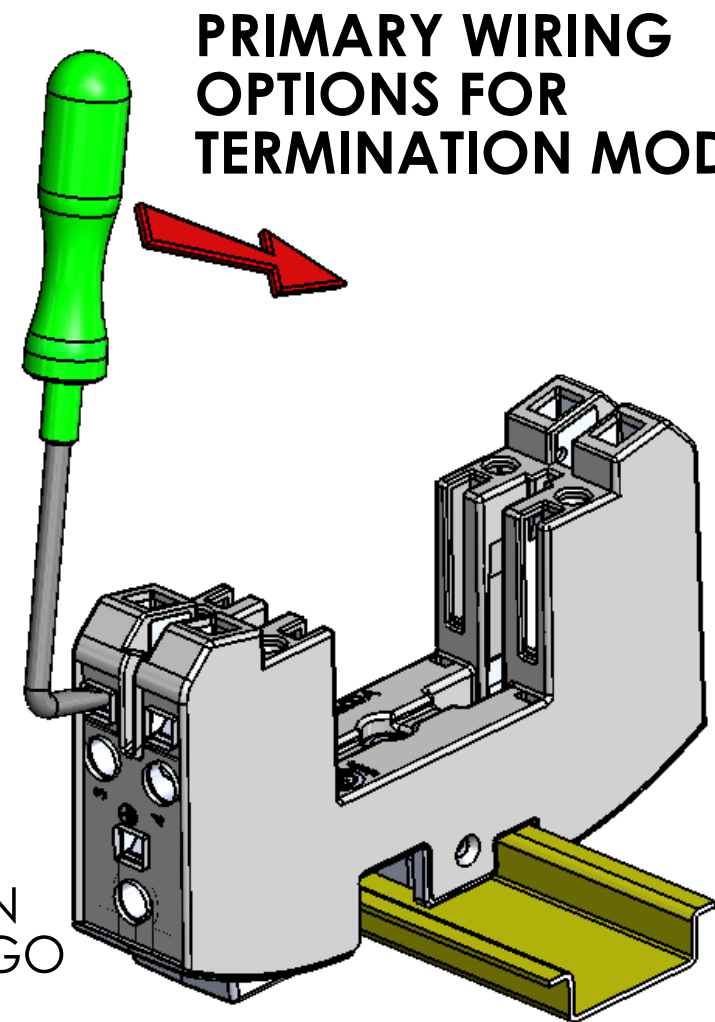

Maximum upward force
• 25N

LEVER THE SCREWDRIVER TOWARDS THE TERMINATION MODULE TO OPEN THE WAGO CAGE CLAMP

3

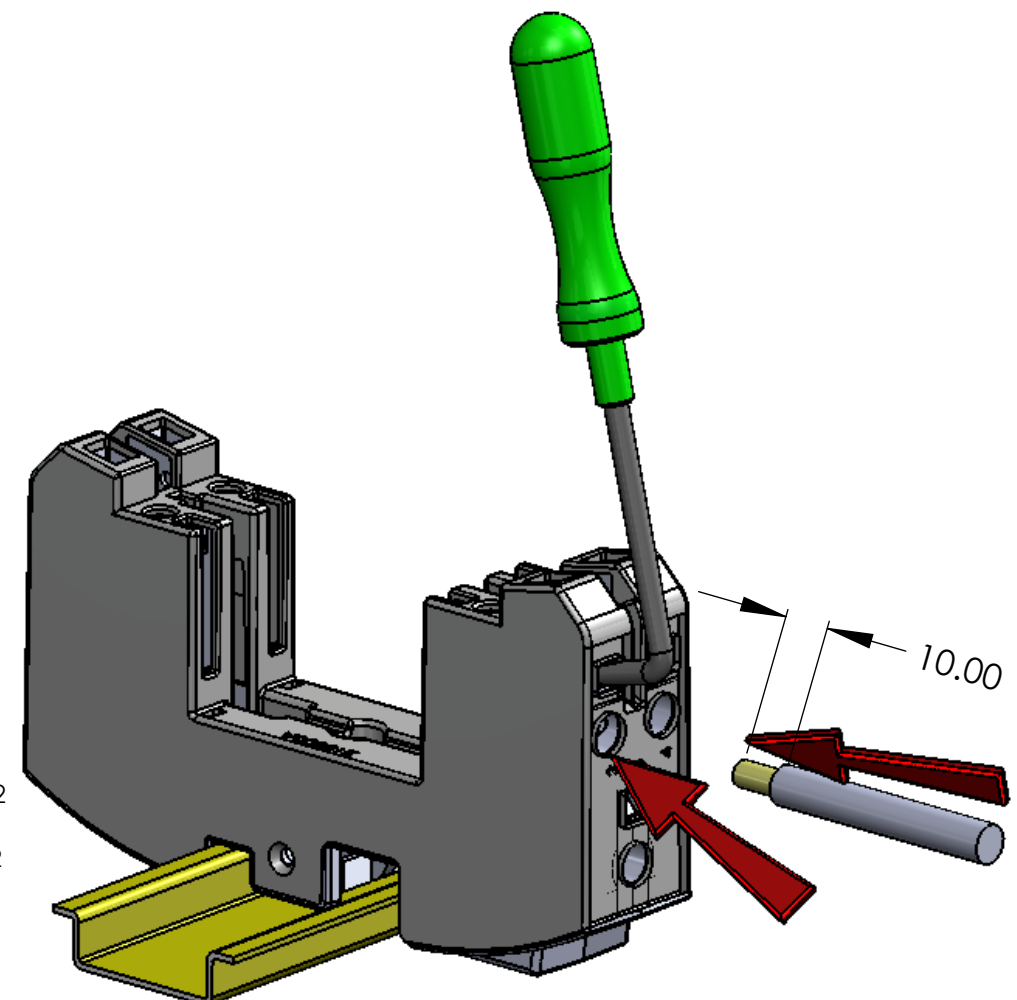

Wire strip length
• 10.00mm

Wire cross sectional area
• Maximum 6.0 mm²
• Minimum 0.75 mm²

INSERT WIRE INTO THE WAGO CAGE CLAMP AND REMOVE SCREWDRIVER

4

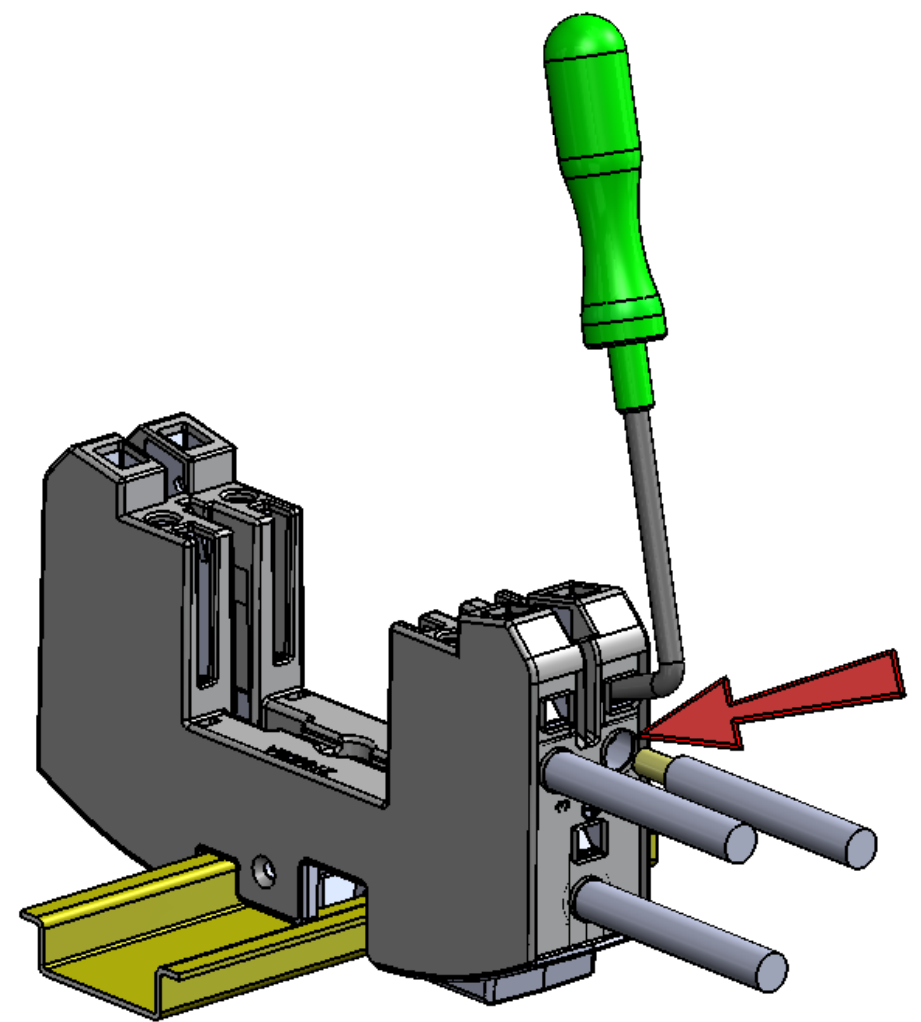

REPEAT OPERATION FOR ALL WIRE TERMINATIONS AS REQUIRED

1

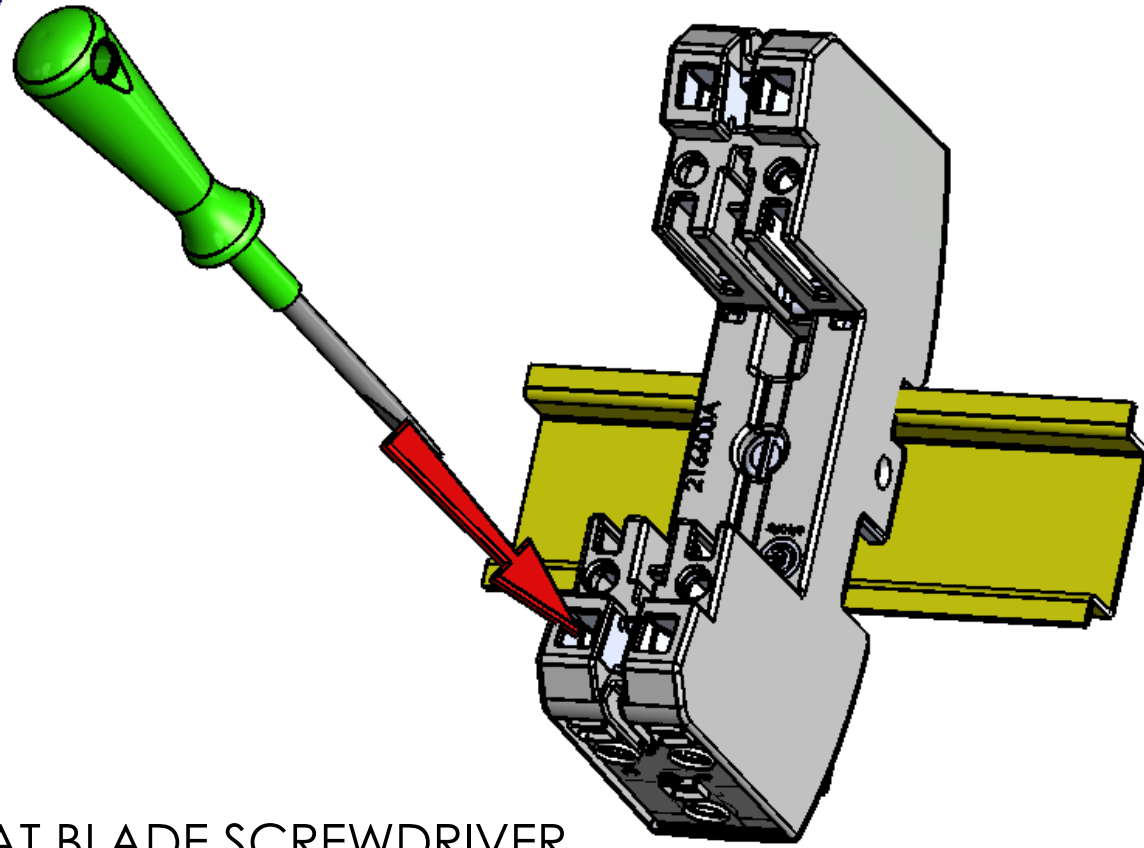

INSERT FLAT BLADE SCREWDRIVER WITH MAXIMUM 3.8mm Ø NECK INTO TOP RELEASE APERTURE

2

Maximum downward force
 • 100N

Advisory note:
 Due to the force required when using this wiring option, consideration should be made to support the rear of the SAM Termination Module, during the application of force, to avoid potential distortion of the DIN rail

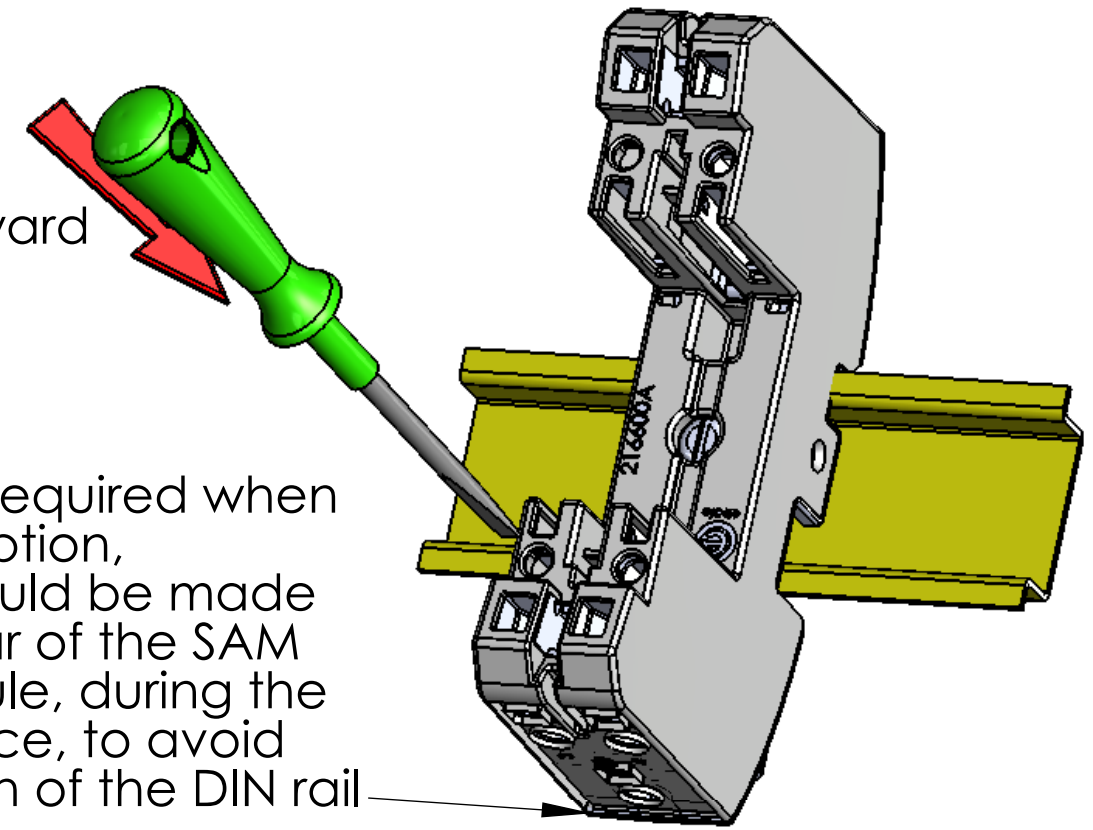

PUSH THE SCREWDRIVER DOWNWARD TO OPEN THE WAGO CAGE CLAMP

ALTERNATIVE WIRING OPTIONS FOR TERMINATION MODULE

3

Wire strip length
 • 10.00mm

Wire cross sectional area
 • Maximum 6.0 mm²
 • Minimum 0.75 mm²

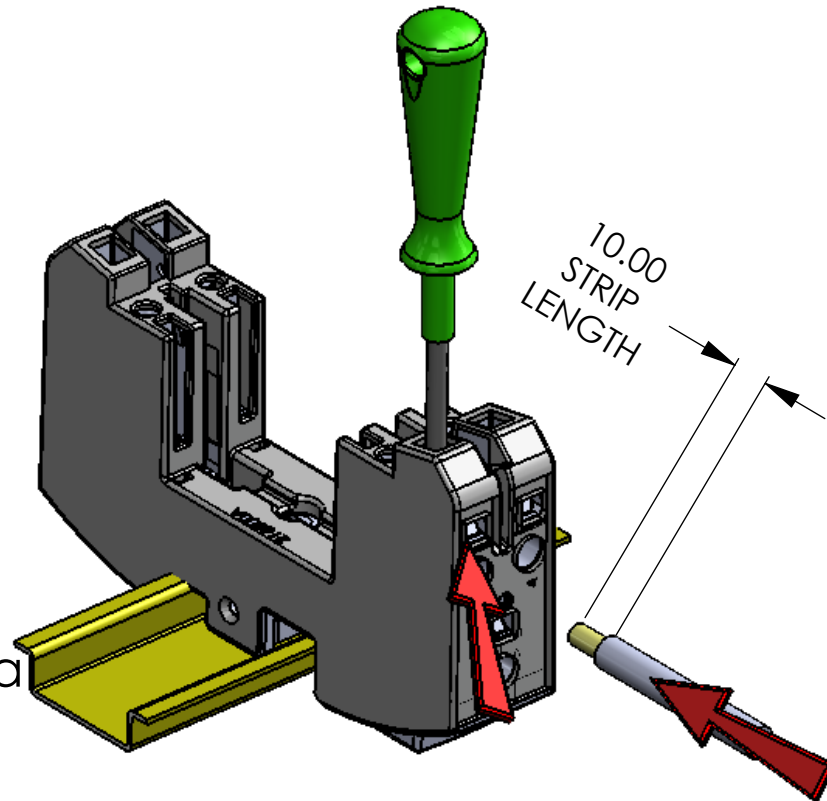

INSERT WIRE INTO THE WAGO CAGE CLAMP AND REMOVE SCREWDRIVER

4

REPEAT OPERATION FOR ALL WIRE TERMINATIONS AS REQUIRED

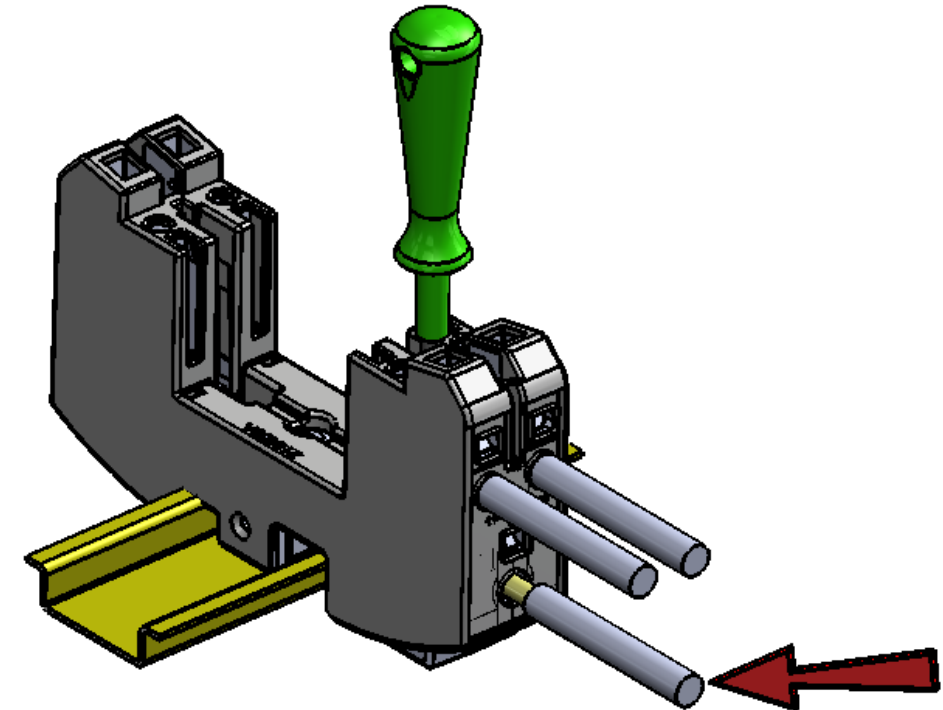

Introducing the Cable Reducer for use with Elsafe's SAM Termination Modules (216600A and 216605A).

Features:

- Allows up to 16mm² cable to be inserted into the Elsafe SAM Base which previously only accepted up to 6mm² cables.
- Thicker wires allow longer circuit runs and/or higher currents.
- Increased design flexibility to keep 'clean' and 'dirty' wiring separated.
- Neater wiring, as you can go directly into the SAM Base without needing to go into a separate terminal.

Crimping:

Can be done with a number of different tools. For example from the Utilux Range:

- Crimp #18, #20, #21, #22, #111, #38A, #98, #41A, #38ROBO
- Using die sets: 38-63CU and CDC16.

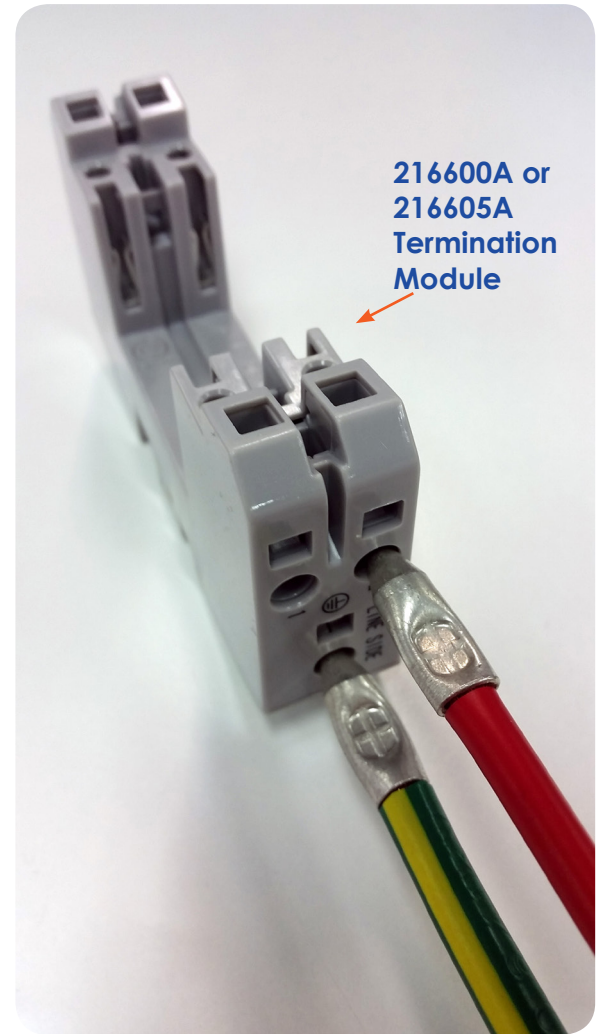
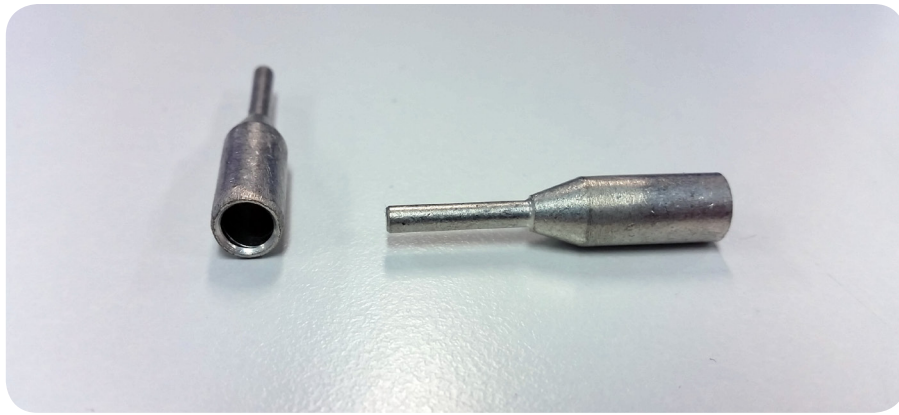

Drawings:

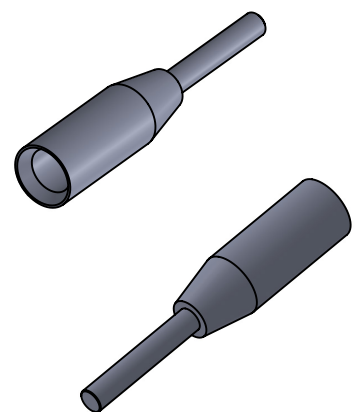
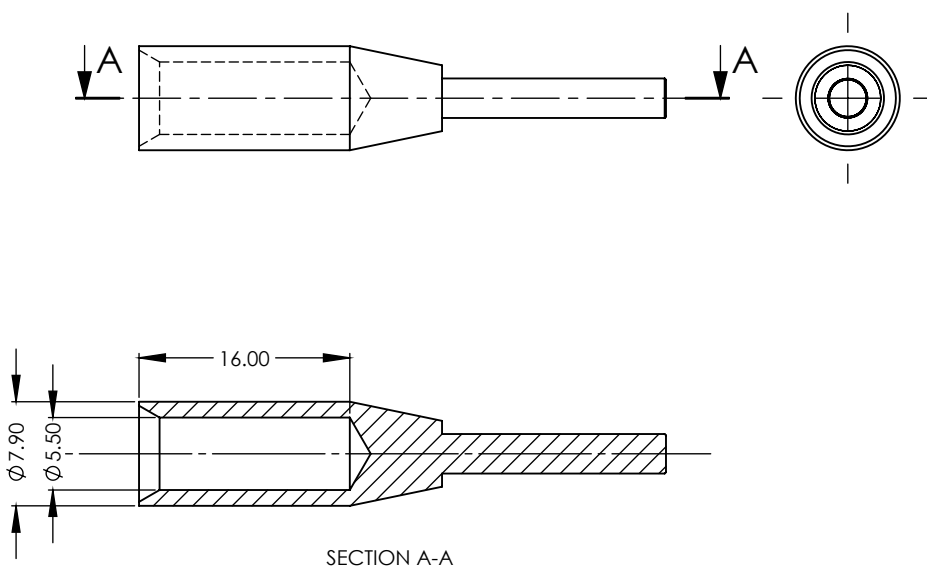

Elsafe Item Numbers:

SAM MARKER T BAR DIGIT 'X' (0 to 9) 496100 to 496109

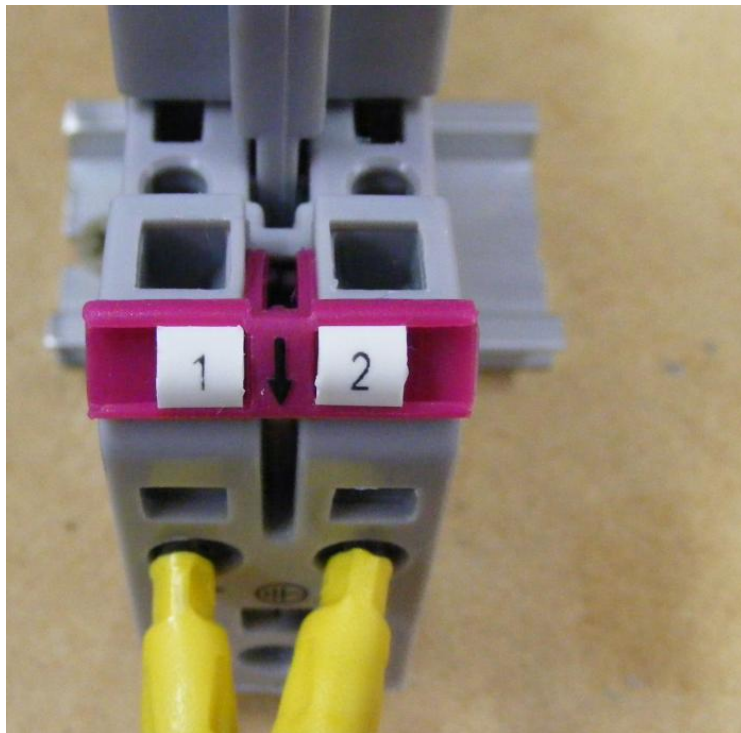

Phoenix Connectors:

- Item Number 0818153 – Blank Sheet that can be printed by Phoenix on request. (to print sheet approx \$15.59)

Zack Marker strip, flat - ZBF 5:UNBEDRUCKT - 0808642

<https://www.phoenixcontact.com/online/portal/au?uri=pxc-oc-itemdetail:pid=0808642&library=auen&tab=1>



G:\Engineering\SAMT-Bars

Page 1 of 2

Element 14:

- Item Number: 8333564

PHOENIX CONTACT 0808671 ZACK STRIP, 1-10



Be The First To Review This Product

[Write A Review](#)



Manufacturer: PHOENIX CONTACT
Order Code: 8333564
Manufacturer Part No 0808671

 [Technical Data Sheet \(19.96KB\) EN](#)

G:\Engineering\SAM\T-Bars

556300 – SAM Voltage Tester

SAM Voltage Tester is a portable, battery-operated tester designed to measure the clamping voltage and DC breakdown voltage of most surge protective devices. It is specifically designed to test the Elsafe range of SAM cassettes, and also has the capability to test other devices. It is suitable for testing gas tubes, carbon gaps, MOVs, Zener and avalanche diodes and thyristor devices, both as components and as complete protectors.

Included are the following termination modules for simple connection to Elsafe products:

- 216600A – FOR MOST SAM CASSETTES
- 216605A – FOR VZC SAM CASSETTES
- 557022 – FOR EQUALISING ARRESTOR MODULE
- 108816 – FOR SSI MKII MODULES 108815 (This base is no longer sold)
- Plugs and flexible leads for testing other devices.

A test matrix is supplied which lists the range of acceptable clamping voltages for each Elsafe product. Due to the nature of surge arresting components, each transient that a SAM cassette is subjected to, shortens the lifetime and degrades the performance of the internal components. The clamping voltages of the internal surge protecting components change after each surge, indicating internal damage. For optimal performance and reliable surge protection it is strongly recommended that the SAM cassette be replaced if the measured clamping value is outside of the specified tolerances shown in the test matrix. Please note that the protection offered by cassettes with display flags may be degraded even if the red flag is not showing.



Specifications

Open Circuit Voltage Rate of Rise	1000 V/s
Maximum Output Voltage	1400 V
Useable Measuring Range	10-1400 V
Test Current for Clamping Devices	1 mA \pm 10 %
Operating Temperature	0 to +50 °C
Storage Temperature	-10 to +60 °C
Measurement Accuracy	0.5 %
Battery Life	Up to 10,000 tests per charge
Size	410(W)x332(D)x155(H) mm

Testing Procedure:



1. Find the SAM Module that needs to be tested in the Test Matrix.
2. Select the correct test according to the Test Matrix via the **TEST SELECTOR**.
3. Press and hold **TEST** button until the green TEST OK LED lights up.
4. Check the voltage shown is within the range shown on the Test Matrix, if it is not replace the SAM module.
5. If more than one test is required by the Test Matrix then proceed to the next test and return to step 2.
6. Complete all recommended tests according to the test matrix.
7. Switch Selector to OFF position and remove the test SAM, tester will automatically **DISCHARGE** the cassette.

556300 continued

For all other devices select TEST 6 (External Banana Connections)

1. Connect the test leads to the banana connections and the other end to the unit under test.
2. Press and hold the **TEST** button until the green TEST OK LED lights up, this is the clamping voltage.
3. Switch Selector to OFF position, disconnect test leads from unit under test.



WARNING! When using the external connectors it is possible to be exposed to a hazardous voltage and there is a risk of electric shock.



Charging Procedure

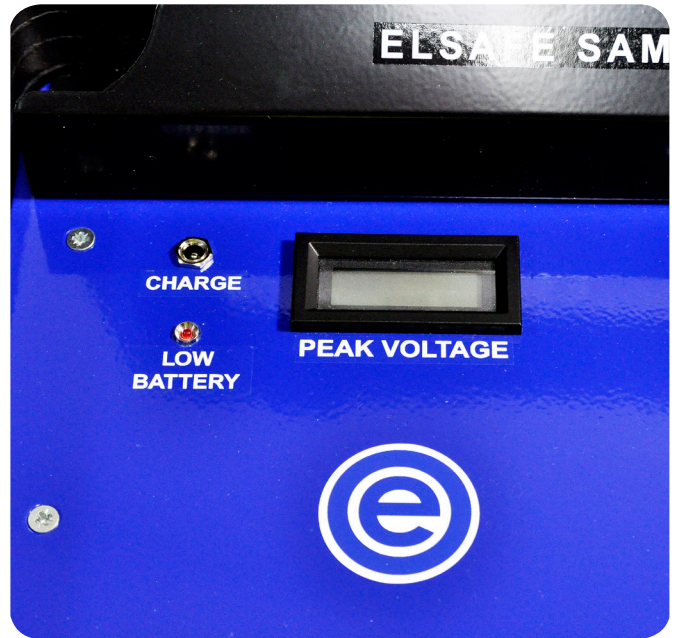

- If the **LOW BATTERY** LED lights up when testing a SAM module this indicated that the internal battery needs to be charged.
- Plug the supplied charger into the mains supply and the other side into the Sam Voltage Tester **CHARGE** port.
- The LED on the Charger should turn **RED**.
- Charging is complete when the LED on the Charger turns **GREEN**
- When testing the high voltage clamping cassettes the battery will need to be fully charged.

Charger Specifications

Rated Input Voltage	100-240Vac
Rated Input Current	0.2 A _{rms}
Output Voltage (DC)	16.8V
Output Current	0.7A
Battery Type	Li-ion 4 Cells

elsafe

Version: OCT 2022

ElSAFE, Unit 2, 11-17 Wilmette Place,
Mona Vale NSW 2103, Australia
Tel: 1300 357 233 Fax: +61 2 9454 7505
sales@oelsafe.com.au <https://railways.elsafe.com.au/>

OE House, Calder Park, Thomas Maddison Lane,
Durkar, Wakefield, WF4 3GH
Tel: +44 (0) 1924 367255 Fax: +44 (0) 1924 290652
sales@oelectrics.co.uk <https://oelectrics.co.uk/>



216620 - Thru Link Cassette

The cassette provides through links between input and output with no additional circuitry. The pass through Connectors are made of silver plated brass with a minimum Cross-Sectional area of 11.9mm². This cassette is rated for 30A through current.

Mechanical & Environmental

Termination Module	Elsafe 216600A
Dimensions	62mm (D) x 110mm (L) x 24mm (W)
Operating Temperature	-20°C to + 75°C
Storage Temperature	-40°C to + 85°C
Relative Humidity	Up to 95%
Fire Rating	94 V0
Weight	100g
Housing Material	Polycarbonate

Circuit Diagram

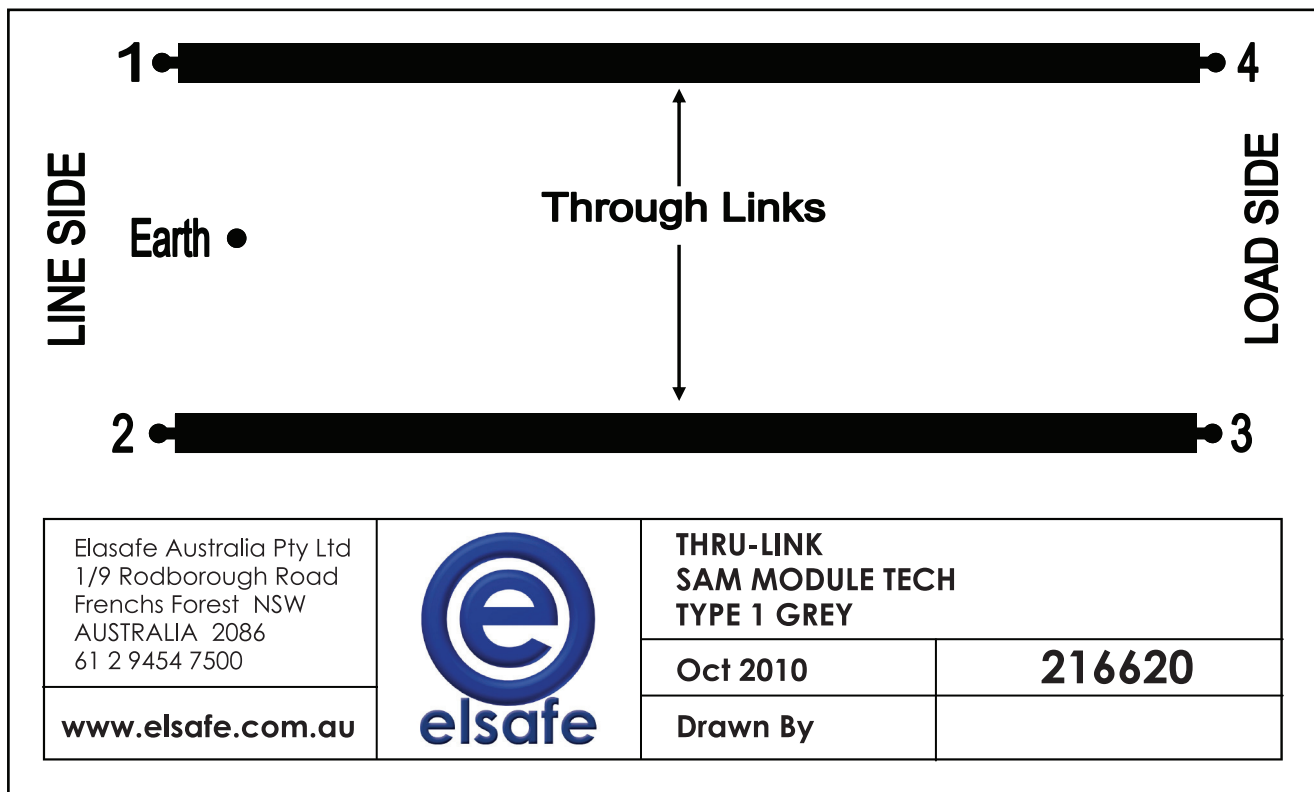

Window Label



216621 - SAFETY ISOLATION CASSETTE

This cassette is used to isolate a circuit when a SAM cassette is removed from a termination module. There are **NO INTERNAL CONNECTIONS**. The intended use is to fill installed SAM termination modules during maintenance, commissioning, or any situation where a wired up SAM termination module is left empty.

Mechanical & Environmental

Termination Module	Elsafe 216600A
Dimensions	62mm (D) x 110mm (L) x 24mm (W)
Operating Temperature	-20°C to + 75°C
Storage Temperature	-40°C to + 85°C
Relative Humidity	Up to 95%
Fire Rating	94 V0
Weight	100g
Housing Material	Polycarbonate

Window Label

216625 - AWS BACK-EMF SNUBBER CASSETTE

The function of the Elsafe 216625 cassette is to suppress Back-EMF that may arise during the normal operation of Automatic Warning Systems (AWS) such as commonly deployed on railways. The cassette plugs into an Elsafe 216600A Termination Module.

The cassette comprises of a diode reverse-connected across the AWS supply rails and a bidirectional transorb diode across the lines. The diode conducts back EMF and the transorb ensures that the reverse bias voltage limit on the diode is not exceeded. Connection through pins 2-3 are intended to be positive.

The pass through connectors are made of plated brass with a minimum cross-sectional area of 11.9mm².

Electrical Specification

Parameter	Values	Units
Maximum Diode Forward Current	6	A
Maximum Applied Voltage	190	Vdc
Maximum Through Current	30	A
Diode Forward Voltage @ 6A	1.3	V

Bi-Directional Transorb Specifications

Parameter	Value	Units
Bi-Direction Transorb Breakdown Voltage	200 ± 5%	V
Maximum Clamping Voltage (10/1000µS)	274	V
Maximum Peak Current (10/1000µS)	5.5	A
Peak Power Dissipation	1500	W
Typical Capacitance @ 1kHz	675	pF

Mechanical & Environmental Specifications

Termination Module	Elsafe 216600A
Dimensions	62mm (D) x 110mm (L) x 24mm (W)
Operating Temperature	-20°C to + 75°C
Storage Temperature	-40°C to + 85°C
Relative Humidity	Up to 95%
Fire Rating	94 V0
Weight	100g
Housing Material	Polycarbonate

Window Label



216630 – Filter & Transient Protection Cassette

The 216630 Filter & Transient Protection Cassette provides both transient protection and low-pass filtering, protecting DC circuits from both surges and high-frequency noise. The line side is protected by two GDTs, between the inputs and to earth, and the load side by a metal oxide varistor (MOV), with filtering in between. To enhance performance a propriety capacitor has been developed to reduce the let through voltage and to meet the railways failsafe circuitry requirements.

The Cassette features an indicator window which is normally green, indicating that it is fit for service. Should there ever be a transient that stresses the internal MOV beyond its safe rating the indicator window will turn red. This indicates that the Cassettes have been over stressed and **MUST** be replaced.

Electrical Specifications

Parameter	Value	Units
Current Rating	100	mA
Nominal Voltage Rating	30	V dc
Cutoff Frequency (3dB)	20	Hz
Loop Resistance	400	Ω

Line-Side Gas Discharge Tube Specifications

Parameter	Value	Units
DC Spark-Over Voltage	350 \pm 15%	V
Impulse Spark-Over Voltage (1KV/ μ S)	\leq 900	V
Surge Discharge Current (10/1000 μ s)	200	A
Surge Discharge Current (8/20 μ s)	20	kA
AC Discharge Current (@50Hz)	20	A
Insulation Resistance	>10	G Ω
Capacitance (1MHz)	\leq 1.5	pF
Arc Voltage (@ 1A)	\sim 25	V

Internal-Side Metal Oxide Varistor Specifications

Parameter	Value	Units
Varistor Clamping Voltage (1mA)	200 \pm 10%	V
Clamping Voltage (100A)	340	V
Capacitance	2	nF
Energy (10/1000 μ s)	140	J
Energy (2ms)	100	J
Peak Current (8/20 μ s)	10	kA

Mechanical & Environmental Specifications

Termination Module	Elsafe 216600A
Dimensions	62mm (D) x 110mm (L) x 24mm (W)
Operating Temperature	-20°C to + 75°C
Storage Temperature	-40°C to + 85°C
Relative Humidity	Up to 95%
Fire Rating	94 V0
Weight	100g
Housing Material	Polycarbonate

Approvals

Agency	Approval Number
PTA (WA)	PRS 34
ARTC	08-08-10-077
RailCorp	★12/0905



216640 – Filter & Transient Protection Cassette

The 216640 Filter & Transient Protection Cassette provides both transient protection and low-pass filtering, protecting DC circuits from both surges and high-frequency noise. The line side is protected by two GDTs, between the inputs and to earth, and the load side by a metal oxide varistor (MOV), with filtering in between. To enhance performance a propriety capacitor has been developed to reduce the let through voltage and to meet the railways failsafe circuitry requirements.

The Cassette features an indicator window which is normally green, indicating that it is fit for service. Should there ever be a transient that stresses the internal MOV beyond its safe rating the indicator window will turn red. This indicates that the Cassettes have been over stressed and **MUST** be replaced.

Electrical Specifications

Parameter	Value	Units
Maximum Peak Current Rating	30	mA
Nominal Voltage Rating	50	V dc
Cutoff Frequency (3dB)	2.7	Hz
Loop Resistance	3	kΩ

Line-Side Gas Discharge Tube Specifications

Parameter	Value	Units
DC Spark-Over Voltage	350 ± 15%	V
Impulse Spark-Over Voltage (1KV/μS)	≤900	V
Surge Discharge Current (10/1000μs)	200	A
Surge Discharge Current (8/20μs)	20	kA
AC Discharge Current (@50Hz)	20	A
Insulation Resistance	>10	GΩ
Capacitance (1MHz)	≤1.5	pF
Arc Voltage (@ 1A)	~25	V

Internal-Side Metal Oxide Varistor Specifications

Parameter	Value	Units
Varistor Clamping Voltage (1mA)	200 ± 10 %	V
Clamping Voltage (100A)	340	V
Capacitance	2	nF
Energy (10/1000μs)	140	J
Energy (2ms)	100	J
Peak Current (8/20μs)	10	kA

Mechanical & Environmental Specifications

Termination Module	Elsafe 216600A
Dimensions	62mm (D) x 110mm (L) x 24mm (W)
Operating Temperature	-20°C to + 75°C
Storage Temperature	-40°C to + 85°C
Relative Humidity	Up to 95%
Fire Rating	94 V0
Weight	100g
Housing Material	Polycarbonate

Approvals

Agency	Approval Number
Queensland Rail	C0040
ARTC	08-08-10-077

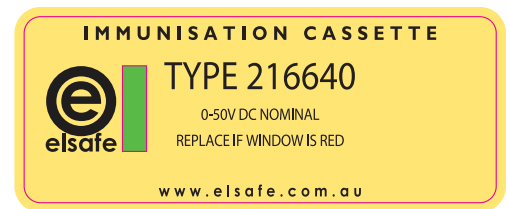

216643 – Filter & Transient Protection Cassette

The 216643 Filter & Transient Protection Cassette provides both transient protection and low-pass filtering, protecting DC circuits from both surges and high-frequency noise. The line side is protected by two GDTs, between the inputs and to earth, and the load side by a metal oxide varistor (MOV), with filtering in between. To enhance performance a propriety capacitor has been developed to reduce let through voltage and to meet the railways failsafe circuitry requirements. This cassette has additional self resetting fuses which open up in the case of a sustained over current.

The Cassette features an indicator window which is normally green, indicating that it is fit for service. Should there ever be a transient that stresses the internal MOV beyond its safe rating the indicator window will turn red. This indicates that the Cassettes have been over stressed and **MUST** be replaced.

Electrical Specifications

Parameter	Value	Units
Peak Maximum Current Rating	30	mA
Voltage Rating	50	V dc
Cutoff Frequency (3dB)	2.7	Hz
Loop Resistance	3	kΩ

Polyswitch Specifications

Parameter	Value	Units
Maximum Voltage	72	V dc
Hold Current (@ 20°C)*	300	mA
Trip Current	600	mA
Maximum Current	40	A

* See graph for other temperatures

Line-Side Gas Discharge Tube Specifications

Parameter	Value	Units
DC Spark-Over Voltage	350 ± 15%	V
Impulse Spark-Over Voltage (1KV/μS)	≤900	V
Surge Discharge Current (10/1000μs)	200	A
Surge Discharge Current (8/20μs)	20	kA
AC Discharge Current (@50Hz)	20	A
Insulation Resistance	>10	GΩ
Capacitance (1MHz)	≤1.5	pF
Arc Voltage (@ 1A)	~25	V

Internal-Side Metal Oxide Varistor Specifications

Parameter	Value	Units
Load-Side Metal Oxide Varistor	200 ± 10%	V
Clamping Voltage	340	V
Capacitance	2	nF
Energy (10/1000μs)	140	J
Energy (2ms)	100	J
Peak Current (8/20μs)	10	kA

Mechanical & Environmental Specifications

Termination Module	Elsafe 216600A
Dimensions	62mm (D) x 110mm (L) x 24mm (W)
Operating Temperature	-20°C to + 75°C
Storage Temperature	-40°C to + 85°C
Relative Humidity	Up to 95%
Fire Rating	94 V0
Weight	100g
Housing Material	Polycarbonate

Self-Resting Fuse

The maximum current rating for the cassette featuring self-resetting fuses must be derated for elevated temperatures, according to the curve below -

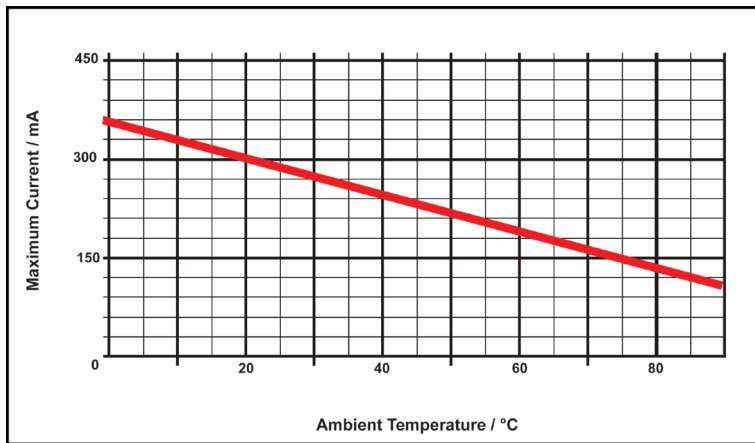

Approvals

Agency	Approval Number
RailCorp NSW	★ 12/0301



216645 – Filter & Transient Protection Cassette

The 216645 Filter & Transient Protection Cassette provides both transient protection and low-pass filtering, protecting DC circuits from both surges and high-frequency noise. The line side is protected by two GDTs, between the inputs and to earth, and the load side by a metal oxide varistor (MOV), with filtering in between. To enhance performance a propriety capacitor has been developed to reduce let through voltage and meet the railways failsafe circuitry requirements. This cassette has an additional self resetting fuse which opens up circuit in the case of a sustained over current.

The Cassette features an indicator window which is normally green, indicating that it is fit for service. Should there ever be a transient that stresses the internal MOV beyond its safe rating the indicator window will turn red. This indicates that the Cassettes have been over stressed and MUST be replaced.

Electrical Specifications

Parameter	Value	Units
Maximum Peak Current Rating	30	mA
Nominal Voltage Rating	50	V dc
Cutoff Frequency (3dB)	2.7	Hz
Loop Resistance	3	kΩ

Polyswitch Specifications

Parameter	Value	Units
Maximum Voltage	60	V dc
Hold Current (@ 20°C)*	1600	mA
Trip Current	3200	mA
Maximum Current	40	A

* See graph for other temperatures

Line-Side Gas Discharge Tube Specifications

Parameter	Value	Units
DC Spark-Over Voltage	350 ± 15%	V
Impulse Spark-Over Voltage (1KV/μS)	≤900	V
Surge Discharge Current (10/1000μs)	200	A
Surge Discharge Current (8/20μs)	20	kA
AC Discharge Current (@50Hz)	20	A
Insulation Resistance	>10	GΩ
Capacitance (1MHz)	≤1.5	pF
Arc Voltage (@ 1A)	~25	V

Internal-Side Metal Oxide Varistor Specifications

Parameter	Value	Units
Varistor Clamping Voltage (1mA)	200 ± 10 %	V
Clamping Voltage (100A)	340	V
Capacitance	2	nF
Energy (10/1000μs)	140	J
Energy (2ms)	100	J
Peak Current (8/20μs)	10	kA

Mechanical & Environmental Specifications

Termination Module	Elsafe 216600A
Dimensions	62mm (D) x 110mm (L) x 24mm (W)
Operating Temperature	-20°C to + 75°C
Storage Temperature	-40°C to + 85°C
Relative Humidity	Up to 95%
Fire Rating	94 V0
Weight	100g
Housing Material	Polycarbonate

Self-Resting Fuse

The maximum current rating for the cassette featuring self-resetting fuses must be derated for elevated temperatures, according to the curve below -

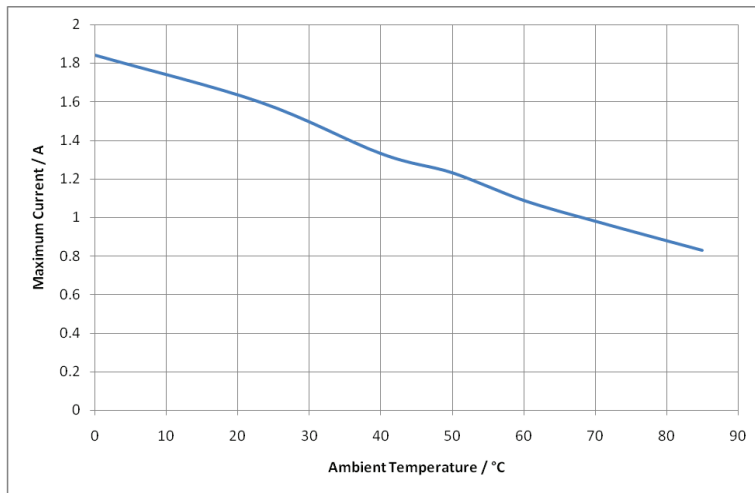

Approvals

Agency	Approval Number
Queensland Rail	C0024a



216653 – Transient Protection Cassette

The 216653 Transient Protection Cassette is fitted with Gas Discharge Tubes (GDT) and Metal Oxide Varistors (MOV) protection between the inputs and also to earth. The GDT and MOV are separated by small value resistors to limit fault current and ensure protection coordination. This cassette has additional self-resetting fuses which open up in the case of a sustained over current.

The Cassette features an indicator window which is normally green, indicating that it is fit for service. Should there ever be a transient that stresses the internal MOV beyond its safe rating the indicator window will turn red. This indicates that the Cassettes have been over stressed and **MUST** be replaced.

Electrical Characteristics

Parameter	Value	Units
Rated Working Voltage	24	V DC
Nominal Breakdown Voltage	42	V
Rated Current (@20°C)	1.5	A
Loop resistance	<1.5	Ω

Polyswitch Specifications

Parameter	Value	Units
Maximum Voltage	60	V dc
Hold Current (@ 20°C)*	1600	mA
Trip Current	3200	mA
Maximum Current	40	A

* See graph for other temperatures

Line-Side Gas Discharge Tubes

Parameter	Value	Units
DC Breakdown Voltage	75 ± 15%	V
Impulse Breakdown Voltage (1kV/μs)	≤650	V
AC Discharge Current (50Hz)	20	A
Surge Discharge Current (10/1000μs)	200	A
Surge Discharge Current (8/20μs)	20	kA
Insulation Resistance	>10	GΩ
Capacitance (1MHz)	≤1.5	pF
Arc Voltage at 1A	~15-25	V

Load-Side Metal Oxide Varistors

Parameter	Value	Units
Varistor Voltage (1mA)	47 ± 10%	V
Maximum Applied Voltage (AC)	30	V _{rms}
Maximum Applied Voltage (DC)	38	V
Clamping Voltage (20A)	93	V
Capacitance	4300	pF
Energy (10/1000μs)	17	J
Energy (2ms)	11.9	J
Peak Current (8/20μs)	2	kA

Mechanical & Environmental Specifications

Termination Module	Elsafe 216600A
Dimensions	62mm (D) x 110mm (L) x 24mm (W)
Operating Temperature	-20°C to + 75°C
Storage Temperature	-40°C to + 85°C
Relative Humidity	Up to 95%
Fire Rating	94 V0
Weight	100g
Housing Material	Polycarbonate

Self-Resetting Fuses

The maximum current rating for cassettes featuring self-resetting fuses must be derated for elevated temperatures, according to the curve below.

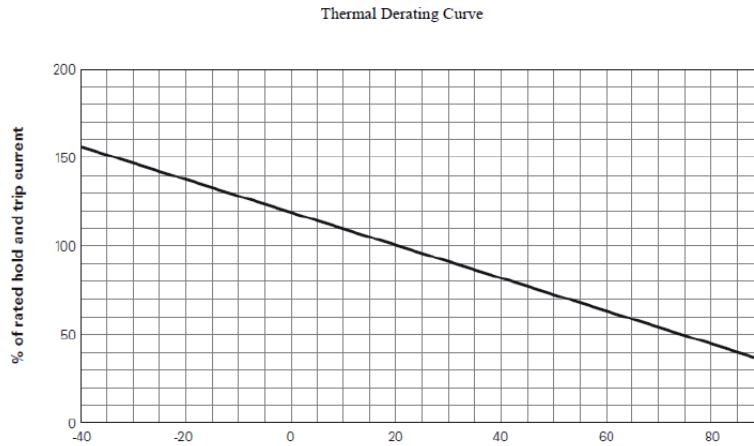

Temperature Derating Graph

*Please note the above graph is the average trip current and may vary up to ± 20%.

Approvals

Agency	Approval Number

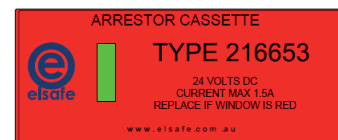

216655 – Transient Protection Cassette

The 216655 Transient Protection Cassette is fitted with Gas Discharge Tubes (GDT) and Metal Oxide Varistors (MOV) protection between the inputs and also to earth. The GDT and MOV are separated by small value resistors to limit fault current and ensure protection coordination. This cassette has additional self-resetting fuses which open up in the case of a sustained over current.

The Cassette features an indicator window which is normally green, indicating that it is fit for service. Should there ever be a transient that stresses the internal MOV beyond its safe rating the indicator window will turn red. This indicates that the Cassettes have been over stressed and **MUST** be replaced.

Electrical Characteristics

Parameter	Value	Units
Rated Working Voltage	50	V
Nominal Breakdown Voltage	90	V
Rated Current (@20°C)	1.2	A
Loop resistance	<1.5	Ω

Polyswitch Specifications

Parameter	Value	Units
Maximum Voltage	60	V dc
Hold Current (@ 20°C)*	1600 ± 20%	mA
Trip Current	3200	mA
Maximum Current	40	A

* See graph for other temperatures

Line-Side Gas Discharge Tubes

Parameter	Value	Units
DC Breakdown Voltage	90 ± 15%	V
Impulse Breakdown Voltage (1kV/μs)	≤650	V
AC Discharge Current (50Hz)	20	A
Surge Discharge Current (10/1000μs)	200	A
Surge Discharge Current (8/20μs)	20	kA
Insulation Resistance	>10	GΩ
Capacitance (1MHz)	≤1.5	pF
Arc Voltage at 1A	~15-25	V

Load-Side Metal Oxide Varistors

Parameter	Value	Units
Varistor Voltage (1mA)	120 ± 10%	V
Maximum Applied Voltage (AC)	75	V _{rms}
Maximum Applied Voltage (DC)	100	V
Clamping Voltage (100A)	200	V
Capacitance	1700	pF
Energy (10/1000μs)	40	J
Energy (2ms)	30	J
Peak Current (8/20μs)	6	kA

Mechanical & Environmental Specifications

Termination Module	Elsafe 216600A
Dimensions	62mm (D) x 110mm (L) x 24mm (W)
Operating Temperature	-20°C to + 75°C
Storage Temperature	-40°C to + 85°C
Relative Humidity	Up to 95%
Fire Rating	94 V0
Weight	100g
Housing Material	Polycarbonate

Self-Resetting Fuses

The maximum current rating for cassettes featuring self-resetting fuses must be derated for elevated temperatures, according to the curve below.

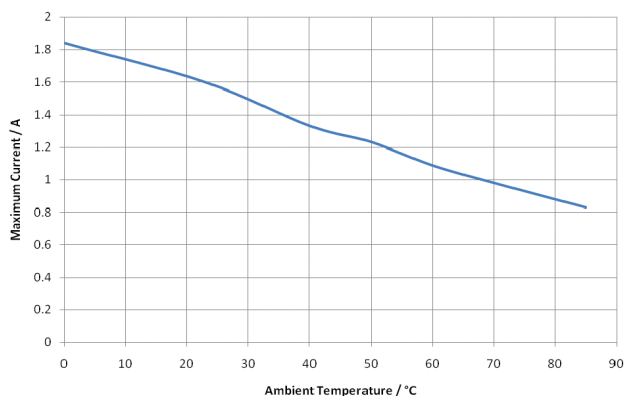

Approvals

Agency	Approval Number
ARTC	08-08-10-077



elsafe

Version: OCT 2022

Elsafe, Unit 2, 11-17 Wilmette Place,
Mona Vale NSW 2103, Australia
Tel: 1300 357 233 Fax: +61 2 9454 7505
sales@oeelsafe.com.au <https://railways.elsafe.com.au/>

OE House, Calder Park, Thomas Maddison Lane,
Durkar, Wakefield, WF4 3GH
Tel: +44 (0) 1924 367255 Fax: +44 (0) 1924 290652
sales@oeelectrics.co.uk <https://oeelectrics.co.uk/>



216660 – Transient Protection Cassette

The 216660 Transient Protection Cassette is fitted with Gas Discharge Tubes (GDT) and Metal Oxide Varistors (MOV) protection between the inputs and also to earth. The GDT and MOV are separated by small value resistors to limit fault current and ensure protection coordination.

The Cassette features an indicator window which is normally green, indicating that it is fit for service. Should there ever be a transient that stresses the internal MOV beyond its safe rating the indicator window will turn red. This indicates that the Cassettes have been over stressed and **MUST** be replaced.

Electrical Characteristics

Parameter	Value	Units
Rated Working Voltage	110	V
Nominal Breakdown Voltage	270	V
Rated Current	2	A
Loop resistance	940	mΩ

Line-Side Gas Discharge Tubes

Parameter	Value	Units
DC Breakdown Voltage	350 ± 15%	V
Impulse Breakdown Voltage (1kV/μs)	≤900	V
AC Discharge Current (50Hz)	20	A
Surge Discharge Current (10/1000μs)	200	A
Surge Discharge Current (8/20μs)	20	kA
Insulation Resistance	>10	GΩ
Capacitance (1MHz)	≤1.5	pF
Arc Voltage at 1A	~15-25	V

Load-Side Metal Oxide Varistors

Parameter	Value	Units
Varistor Voltage (1mA)	270±10%	V
Maximum Applied Voltage (AC)	175	V _{rms}
Maximum Applied Voltage (DC)	225	V
Clamping Voltage (100A)	455	V
Capacitance	740	pF
Energy (10/1000μs)	99	J
Energy (2ms)	70	J
Peak Current (8/20μs)	6.5	KA

Mechanical & Environmental Specifications

Termination Module	Elsafe 216600A
Dimensions	62mm (D) x 110mm (L) x 24mm (W)
Operating Temperature	-20°C to + 75°C
Storage Temperature	-40°C to + 85°C
Relative Humidity	Up to 95%
Fire Rating	94 V0
Weight	100g
Housing Material	Polycarbonate

Approvals

Agency	Approval Number
Queensland Rail	C0026
ARTC	08-08-10-077



216670 - Fax/Modem Overvoltage Cassette

The Elsafe 216670 technical cassette is specifically designed for the protection of Modem and Fax equipment connected to the PSTN and private cabling systems. The cassette features GDT and MOV surge protection as well as a balanced circuit with internal Inductor-Capacitor filtering.

The Cassettes feature an indicator window which is normally green, indicating that it is fit for service. Should there ever be a transient that stresses the internal MOV beyond its safe ratings the indicator window will turn red. This indicates that the Cassettes have been overstressed, and MUST be replaced.

Electrical Specification

Parameter	Value	Units
Nominal Rated Working Voltage	50	V DC
Maximum Voltage	230	V
Maximum Current	1	A

Line-Side Gas Discharge Tube Specifications

Parameter	Value	Units
DC Spark-Over Voltage	230±15%	V
Impulse Spark-Over Voltage (1kV/μs)	≤700	V
AC Discharge Current (50Hz)	10	A
Surge Discharge Current (10/1000μS)	100	A
Surge Discharge Current (8/20μS)	10	kA
Insulation Resistance	>10	GΩ
Capacitance (1MHz)	≤1.5	pF
Arc Voltage at 1A	~15-25	V

Internal-Side Metal Oxide Varistor Specifications

Parameter	Value	Units
Varistor Voltage (1mA)	270±10%	V
Maximum Applied Voltage (AC _{rms})	175	V _{rms}
Maximum Applied Voltage (DC)	225	V
Clamping Voltage (100A)	455	V
Capacitance	740	pF
Energy (10/1000μs)	99	J
Energy (2ms)	70	J
Peak Current (8/20μs)	6.5	kA

Mechanical & Environmental Specifications

Termination Module	Elsafe 216600A
Dimensions	62mm (D) x 110mm (L) x 24mm (W)
Operating Temperature	-20°C to + 75°C
Storage Temperature	-40°C to + 85°C
Relative Humidity	Up to 95%
Fire Rating	94 V0
Weight	100g
Housing Material	Polycarbonate

Approvals

Agency	Approval No
AUSTEL	A92/83K/0044
ARTC	08-08-10-077

Window Labels

according to the images below

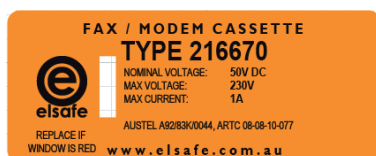

elsafe

Version: OCT 2022

Elsafe, Unit 2, 11-17 Wilmette Place,
Mona Vale NSW 2103, Australia
Tel: 1300 357 233 Fax: +61 2 9454 7505
sales@oeelsafe.com.au <https://railways.elsafe.com.au/>

OE House, Calder Park, Thomas Maddison Lane,
Durkar, Wakefield, WF4 3GH
Tel: +44 (0) 1924 367255 Fax: +44 (0) 1924 290652
sales@oeelectrics.co.uk <https://oeelectrics.co.uk/>



216680 – Transient Protection Cassette

The 216680 Transient Protection Cassette provides protection for high-voltage DC circuits. It is fitted with a three-terminal Gas Discharge Tube (GDT) suppressing excessive voltages between Line or Neutral and Earth.

Electrical Specifications

Parameter	Value	Units
Absolute Maximum Working Voltage	230	V
Breakdown Voltage	290	V
Maximum Current – Series Connected	30	A
Maximum Current – Shunt Connected	200	A
Loop Resistance	<6	mΩ

Gas Discharge Tube Specifications

Parameter	Value	Units
DC Spark-Over Voltage	290±20%	V
Impulse Spark-Over Voltage (1KV/μS)	≤800	V
Nominal Impulse Discharge Current (8/20μs)	30	kA
Single Impulse Discharge Current (8/20μs)	40	kA
Nominal AC Discharge Current	30	A
AC Discharge Current (50Hz, 9 Cycles)	50	A
Insulation Resistance	>10	GΩ
Capacitance (1MHz)	20	pF
Arc Voltage at 1A	~25	V

Mechanical & Environmental Specifications

Termination Module	Elsafe 216600A
Dimensions	62mm (D) x 110mm (L) x 24mm (W)
Operating Temperature	-20°C to + 75°C
Storage Temperature	-40°C to + 85°C
Relative Humidity	Up to 95%
Fire Rating	94 V0
Weight	100g
Housing Material	Polycarbonate

Approvals

Agency	Approval Number
ARTC	08-08-10-077

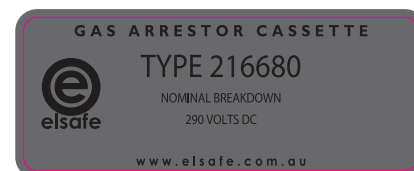

216690 – Transient Protection Cassette

The 216690 Transient Protection Cassette provides protection for high-voltage dc circuits. It is fitted with a three-terminal Gas Discharge Tube (GDT) suppressing excessive voltages between Line or Neutral and Earth.

Electrical Specifications

Parameter	Value	Units
Absolute Maximum Working Voltage	560	V
Nominal Breakdown Voltage	700	V
Maximum Current – Series Connected	30	A
Maximum Current – Shunt Connected	200	A
Loop Resistance	<6	mΩ

Gas Discharge Tube Specifications

Parameter	Value	Units
DC Breakdown Voltage	700±20%	V
Impulse Spark-Over Voltage (1KV/μS)	≤1200	V
Nominal Impulse Discharge Current (8/20μs)	30	kA
Single Impulse Discharge Current (8/20μs)	40	kA
Nominal AC Discharge Current	30	A
AC Discharge Current (50Hz, 9 Cycles)	50	A
Insulation Resistance	>10	GΩ
Capacitance (1MHz)	20	pF
Arc Voltage at 1A	~25	V

Mechanical & Environmental Specifications

Termination Module	Elsafe 216600A
Dimensions	62mm (D) x 110mm (L) x 24mm (W)
Operating Temperature	-20°C to + 75°C
Storage Temperature	-40°C to + 85°C
Relative Humidity	Up to 95%
Fire Rating	94 V0
Weight	100g
Housing Material	Polycarbonate

Approvals

Agency	Approval Number
MTM-PTA	00036

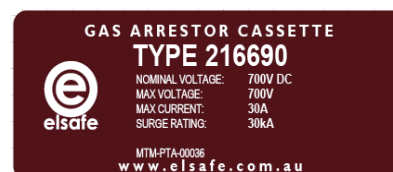

555122 - Transient Protection Cassettes

The 555122 Cassette is a three stage surge protection cassette, featuring Gas Discharge Tube (GDT) and Metal Oxide Varistor (MOV) protection, as well as inductor / current-limiting resistors, self-resetting fuses, and final stage transorb diodes. The GDT is a 3-Pin device that connects to Earth to suppress common mode transients, the other components are between the two input lines forming coordinated differential mode surge protection for low voltage devices.

Electrical Specifications

Parameter	Value	Units
Rated Voltage	12	Vdc
Nominal Clamping Voltage	15.5	V
Current Rating	1500	mA
Loop Resistance	< 1.0	Ω
Loop Inductance	188	μ H

Line-Side Gas Discharge Tube Specifications

Parameter	Value	Units
DC Breakdown Voltage	230 \pm 15%	V
Impulse Breakdown Voltage (1kV/ μ s)	\leq 700	V
AC Discharge Current (50Hz)	10	A
Surge Discharge Current (10/1000 μ S)	100	A
Surge Discharge Current (8/20 μ S)	10	kA
Insulation Resistance	>10	G Ω
Capacitance (1MHz)	\leq 1.5	pF
Arc Voltage at 1A	\sim 15-25	V

Metal Oxide Varistor Specifications

Parameter	Value	Units
Varistor Voltage (1mA)	82 \pm 10%	V
Maximum Applied Voltage (AC _{rms})	50	V
Maximum Applied Voltage (DC)	65	V
Clamping Voltage (100A)	135	V
Capacitance	2400	pF
Energy (10/1000 μ s)	27	J
Energy (2ms)	20.5	J
Peak Current (8/20 μ s)	6.0	kA

Transorb Diode Specifications

Parameter	Value	Units
Bi-Directional Transorb Breakdown Voltage	15 ± 5%	V
Maximum Clamping Voltage (Vc @ I _{pp} - 10/1000μS)	21.2	V
Maximum Peak Pulse Current (I _{pp} - 10/1000μS)	71	A
Peak Power Dissipation	1500	W
Typical Capacitance @1kHz	5000	pF

Self-Resetting Fuse Specifications

The maximum current rating for cassettes featuring self-resetting fuses must be derated for elevated temperatures, according to the curves below.

Parameter	Value	Units
Maximum Voltage	60	Vdc
Hold Current (@ 20°C)	1600	mA
Trip Current	3200	mA
Maximum Current	40	A

Window Labels

according to the images below

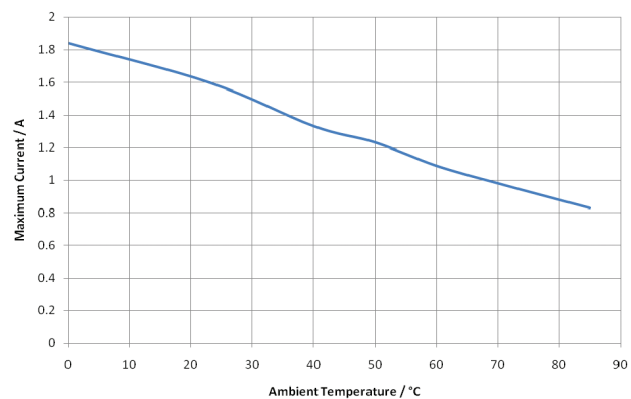

Mechanical & Environmental Specifications

Termination Module	Elsafe 216600A
Dimensions	62mm (D) x 110mm (L) x 24mm (W)
Operating Temperature	-20°C to + 75°C
Storage Temperature	-40°C to + 85°C
Relative Humidity	Up to 95%
Fire Rating	94 V0
Weight	100g
Housing Material	Polycarbonate

elsafe

Version: OCT 2022

Elsafe, Unit 2, 11-17 Wilmette Place,
Mona Vale NSW 2103, Australia
Tel: 1300 357 233 Fax: +61 2 9454 7505
sales@oelsafe.com.au <https://railways.elsafe.com.au/>

OE House, Calder Park, Thomas Maddison Lane,
Durkar, Wakefield, WF4 3GH
Tel: +44 (0) 1924 367255 Fax: +44 (0) 1924 290652
sales@oelectrics.co.uk <https://oelectrics.co.uk/>



555128 - Transient Protection Cassettes

The 555128 Cassette is a three stage surge protection cassette, featuring Gas Discharge Tube (GDT) and Metal Oxide Varistor (MOV) protection, as well as inductor / current-limiting resistors, and final stage transorb diodes. The GDT is a 3-Pin device that connects to Earth to suppress common mode transients, the other components are between the two input lines forming coordinated differential mode surge protection for low voltage devices. The device contains an internal mechanical flag that will change from green to red if the GDT has experienced high stress - indicating the cassette should be replaced.

Electrical Specifications

Parameter	Value	Units
Rated Voltage	24	Vdc
Nominal Clamping Voltage	30.5	V
Current Rating	1500	mA
Loop Resistance	< 1.0	Ω
Loop Inductance	188	μ H

Line-Side Gas Discharge Tube Specifications

Parameter	Value	Units
DC Breakdown Voltage	230 \pm 15%	V
Impulse Breakdown Voltage (1kV/ μ s)	\leq 700	V
AC Discharge Current (50Hz)	10	A
Surge Discharge Current (10/1000 μ S)	100	A
Surge Discharge Current (8/20 μ S)	10	kA
Insulation Resistance	>10	G Ω
Capacitance (1MHz)	\leq 1.5	pF
Arc Voltage at 1A	\sim 15-25	V

Metal Oxide Varistor Specifications

Parameter	Value	Units
Varistor Voltage (1mA)	82 \pm 10%	V
Maximum Applied Voltage (AC _{rms})	50	V
Maximum Applied Voltage (DC)	65	V
Clamping Voltage (100A)	135	V
Capacitance	2400	pF
Energy (10/1000 μ s)	27	J
Energy (2ms)	20.5	J
Peak Current (8/20 μ s)	6.0	kA

Transorb Diode Specifications

Parameter	Value	Units
Bi-Directional Transorb Breakdown Voltage	30 ± 5%	V
Maximum Clamping Voltage (Vc @ I _{pp} - 10/1000μS)	41.4	V
Maximum Peak Pulse Current (I _{pp} - 10/1000μS)	36.7	A
Peak Power Dissipation	1500	W
Typical Capacitance @1kHz	400	pF

Window Labels

according to the images below

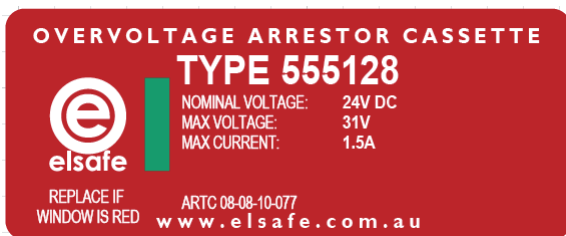

Mechanical & Environmental Specifications

Termination Module	Elsafe 216600A
Dimensions	62mm (D) x 110mm (L) x 24mm (W)
Operating Temperature	-20°C to + 75°C
Storage Temperature	-40°C to + 85°C
Relative Humidity	Up to 95%
Fire Rating	94 V0
Weight	100g
Housing Material	Polycarbonate

elsafe

Version: OCT 2022

Elsafe, Unit 2, 11-17 Wilmette Place,
Mona Vale NSW 2103, Australia
Tel: 1300 357 233 Fax: +61 2 9454 7505
sales@oeelsafe.com.au <https://railways.elsafe.com.au/>

OE House, Calder Park, Thomas Maddison Lane,
Durkar, Wakefield, WF4 3GH
Tel: +44 (0) 1924 367255 Fax: +44 (0) 1924 290652
sales@oeelectrics.co.uk <https://oeelectrics.co.uk/>



555175 – Transient Protection Cassette

The 555175 Transient Protection Cassette is fitted with Gas Discharge Tubes (GDT) and Metal Oxide Varistors (MOV) protection between the inputs and also to earth. The GDT and MOV are separated by small value resistors to limit fault current and ensure protection coordination. This cassette has additional self-resetting fuses which open up in the case of a sustained over current.

The Cassette features an indicator window which is normally green, indicating that it is fit for service. Should there ever be a transient that stresses the internal MOV beyond its safe rating the indicator window will turn red. This indicates that the Cassettes have been over stressed and MUST be replaced.

Electrical Specifications

Parameter	Value	Units
Nominal Working Voltage	50	V
Maximum Rated Voltage	100	V
Maximum Rated Current (@ 20°C)*	1.5	A
Loop resistance	<1.5	Ω

Polyswitch Specifications

Parameter	Value	Units
Maximum Voltage	60	V dc
Hold Current (@ 20°C)*	1600	mA
Trip Current	3200	mA
Maximum Current	40	A

* See graph for other temperatures

Line-Side Gas Discharge Tube Specifications

Parameter	Value	Units
DC Breakdown Voltage	150±15%	V
Impulse Breakdown Voltage (1kV/μs)	≤650	V
AC Discharge Current (50Hz)	20	A
Surge Discharge Current (10/1000μs)	200	A
Surge Discharge Current (8/20μs)	20	KA
Insulation Resistance	>10	GΩ
Capacitance (1MHz)	≤1.5	pF
Arc Voltage (@1A)	~15-25	V

Internal-Side Metal Oxide Varistor Specifications

Parameter	Value	Units
Varistor Clamping Voltage (1mA)	120±10%	V
Maximum Applied Voltage (AC _{rms})	75	V
Maximum Applied Voltage (DC)	100	V
Clamping Voltage (100A)	200	V
Capacitance	1700	pF
Energy (10/1000μs)	40	J
Energy (2ms)	30	J
Peak Current (8/20μs)	6	kA

Mechanical & Environmental Specifications

Termination Module	Elsafe 216600A
Dimensions	62mm (D) x 110mm (L) x 24mm (W)
Operating Temperature	-20°C to + 75°C
Storage Temperature	-40°C to + 85°C
Relative Humidity	Up to 95%
Fire Rating	94 V0
Weight	100g
Housing Material	Polycarbonate

Self-Resting Fuse

The maximum current rating for the cassette featuring self-resetting fuses must be derated for elevated temperatures, according to the curve below:

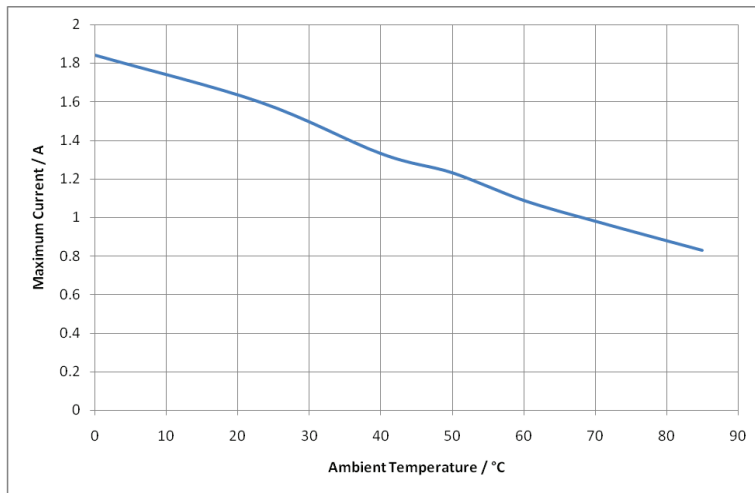

Approvals

Agency	Approval Number
Queensland Rail	C0040b



555191 – Transient Protection Cassette

The 555191 Transient Protection Cassette is fitted with Gas Discharge Tubes (GDT) and Metal Oxide Varistors (MOV) protection between the inputs and also to earth. The GDT and MOV are separated by small value resistors to limit fault current and ensure protection coordination. This cassette has additional self-resetting fuses which open up in the case of a sustained over current. Additionally this cassette has a Bi-Directional Transorb as a final stage for added protection.

The Cassette features an indicator window which is normally green, indicating that it is fit for service. Should there ever be a transient that stresses the internal MOV beyond its safe rating the indicator window will turn red. This indicates that the Cassettes have been over stressed and MUST be replaced.

Electrical Specifications

Parameter	Value	Units
Rated Working Voltage	50	V
Breakdown Voltage	91 ± 5%	V
Rated Current	1.5	A
Loop resistance	<1.5	Ω

Line-Side Gas Discharge Tube Specifications

Parameter	Value	Units
DC Breakdown Voltage	150±15%	V
Impulse Breakdown Voltage (1kV/μs)	≤650	V
AC Discharge Current (50Hz)	20	A
Surge Discharge Current (10/1000μs)	200	A
Surge Discharge Current (8/20μs)	20	KA
Insulation Resistance	>10	GΩ
Capacitance (1MHz)	≤1.5	pF
Arc Voltage at 1A	~(15-25)	V

Internal-Side Metal Oxide Varistor Specifications

Parameter	Value	Units
Varistor Clamping Voltage (1mA)	120±10%	V
Maximum Applied Voltage (AC)	75	V
Maximum Applied Voltage (DC)	100	V
Clamping Voltage (100A)	200	V
Capacitance	1700	pF
Energy (10/1000μs)	40	J
Energy (2ms)	30	J
Peak Current (8/20μs)	6	KA

Bi-Directional Transorb Specifications

Parameter	Value	Units
Bi-Directional Transorb Breakdown Voltage	91 ± 5%	V
Maximum Clamping Voltage (10/1000µS)	125	V
Maximum Peak Current (10/1000µS)	12	A
Peak Power Dissipation	1500	W
Typical Capacitance @1kHz	1150	pF

Mechanical & Environmental Specifications

Termination Module	Elsafe 216600A
Dimensions	62mm (D) x 110mm (L) x 24mm (W)
Operating Temperature	-20°C to + 75°C
Storage Temperature	-40°C to + 85°C
Relative Humidity	Up to 95%
Fire Rating	94 V0
Weight	100g
Housing Material	Polycarbonate

Self-Resting Fuse

The maximum current rating for the cassette featuring self-resetting fuses must be derated for elevated temperatures, according to the curve below -

Parameter	Value	Units
Maximum Voltage	60	Vdc
Hold Current (@ 20°C)*	1600	mA
Trip Current	3200	mA
Maximum Current	40	A

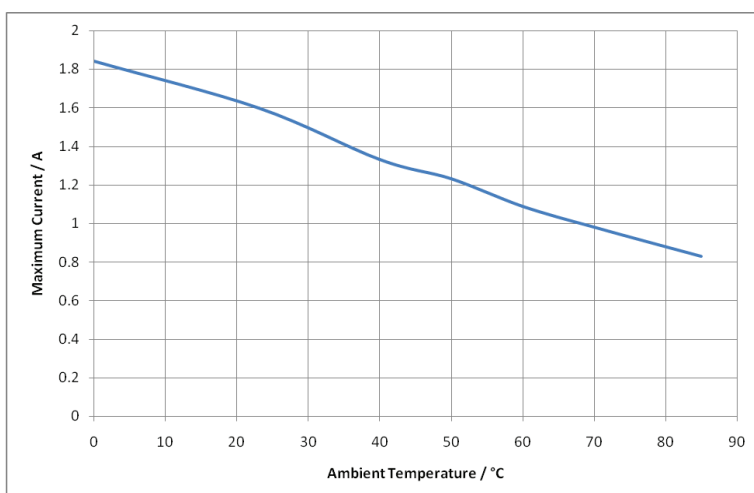

555200– SSI Protection Cassette

The 555200 SSI Data Link Module Protection Cassette features three stages of protection, 3-Terminal Gas Discharge Tube (GDT) to Earth, Metal Oxide Varistor (MOV) and two Bi-Directional Transorbs, each are separate by small value resistance to ensure protection coordination.

The cassette features an indicator window which is normally green, indicating that it is fit for service. Should there ever be a transient that stresses the MOV beyond its safe rating the indicator window will turn red. This indicates that the cassettes have been overstressed, and **MUST** be replaced.

Electrical Specifications

Parameter	Value	Units
Working Voltage	12	V
Nominal Clamping Voltage	15	V
Maximum Current (Peak / Continuous)	1200 / 500	mA
Loop Resistance	8.4	Ω

Gas Discharge Tube Specifications

Parameter	Value	Units
DC Spark-Over Voltage	230 \pm 15%	V
Impulse Spark-Over Voltage (1KV/ μ S)	\leq 700	V
Surge Discharge Current (8/20 μ S)	10	kA
Surge Discharge Current (10/1000 μ S)	100	A
AC Discharge Current (50Hz)	10	A
Insulation Resistance (250V dc)	\geq 10	G Ω
Capacitance (1MHz)	\leq 1.5	pF
Arc Voltage at 1A	\sim 15-25	V

Metal Oxide Varistor Specifications

Parameter	Value	Units
Varistor Clamping Voltage (1mA)	430 \pm 10%	V
Clamping Voltage (@100A Peak)	710	V
Maximum Peak Current (8/20 μ S) – 1 Times	6.5	kA
Maximum Peak Current (8/20 μ S) – 2 Times	5	kA
Maximum Energy (10/1000 μ S)	155	J
Typical Capacitance @ 1kHz	460	pF

Bi-Directional Transorb Specifications

Parameter	Value		Units
	Bi-Direction Transorb Breakdown Voltage	15 \pm 5%	
Maximum Clamping Voltage (10/1000 μ S)	21.2	274	V
Maximum Peak Current (10/1000 μ S)	71	5.5	A
Peak Power Dissipation	1500	1500	W
Typical Capacitance @ 1kHz	5000	675	pF

Mechanical & Environmental Specifications

Termination Module	Elsafe 216600A
Dimensions	62mm (D) x 110mm (L) x 24mm (W)
Operating Temperature	-20°C to + 75°C
Storage Temperature	-20°C to + 85°C
Relative Humidity	Up to 95%
Fire rating	94 V0
Weight	100g
Housing Material	Polycarbonate

Approvals

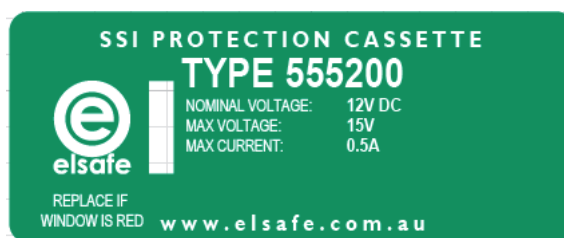

555220– SSI Protection Cassette

The 555220 SSI Data Link Module Protection Cassette features three stages of protection, 3-Terminal Gas Discharge Tube (GDT) to Earth, Metal Oxide Varistor (MOV) and two Bi-Directional Transorbs, each are separate by small value resistance to ensure protection coordination.

The cassette features an indicator window which is normally green, indicating that it is fit for service. Should there ever be a transient that stresses the MOV beyond its safe rating the indicator window will turn red. This indicates that the cassettes have been overstressed, and **MUST** be replaced.

Electrical Specifications

Parameter	Value	Units
Working Voltage	20	V
Nominal Clamping Voltage	22	V
Maximum Current (Peak / Continuous)	1200 / 500	mA
Loop Resistance	8.4	Ω

Gas Discharge Tube Specifications

Parameter	Value	Units
DC Spark-Over Voltage	230 \pm 20%	V
Impulse Spark-Over Voltage (1KV/ μ S)	\leq 800	V
Surge Discharge Current (8/20 μ S)	20	kA
Surge Discharge Current (10/1000 μ S)	100	A
AC Discharge Current (50Hz)	20	A
Insulation Resistance (100V dc)	\geq 1	G Ω
Capacitance (1MHz)	\leq 1.5	pF
Arc Voltage at 1A	\sim 15-25	V

Metal Oxide Varistor Specifications

Parameter	Value	Units
Varistor Clamping Voltage (1mA)	430 \pm 10%	V
Clamping Voltage (@100A Peak)	710	V
Maximum Peak Current (8/20 μ S) – 1 Times	6.5	kA
Maximum Peak Current (8/20 μ S) – 2 Times	5	kA
Maximum Energy (10/1000 μ S)	155	J
Typical Capacitance @ 1kHz	460	pF

Bi-Directional Transorb Specifications

Parameter	Value		Units
	Bi-Direction Transorb Breakdown Voltage	22 \pm 5%	
Maximum Clamping Voltage (10/1000 μ S)	30.6	274	V
Maximum Peak Current (10/1000 μ S)	49	5.5	A
Peak Power Dissipation	1500	1500	W
Typical Capacitance @ 1kHz	3700	675	pF

Mechanical & Environmental Specifications

Termination Module	Elsafe 216600A
Dimensions	62mm (D) x 110mm (L) x 24mm (W)
Operating Temperature	-20°C to + 75°C
Storage Temperature	-20°C to + 85°C
Relative Humidity	Up to 95%
Fire rating	94 V0
Weight	100g
Housing Material	Polycarbonate

Approvals

MTM-PTA-00036	



555275 – Transient Protection Cassette

The 555275 Transient Protection Cassette is fitted with Gas Discharge Tubes (GDT) and Metal Oxide Varistors (MOV) protection between the inputs and also to earth. This cassette is a high current version of the 555175. This cassette has additional self-resetting fuses which open up in the case of a sustained over current. Please note the temperature dependance of this trip current - graph on the following page.

The Cassette features an indicator window which is normally green, indicating that it is fit for service. Should there ever be a transient that stresses the internal MOV beyond its safe rating the indicator window will turn red. This indicates that the Cassettes have been over stressed and **MUST** be replaced.

Electrical Specifications

Parameters	Value	Units
Rated Working Voltage	50	Vdc
Absolute Maximum Current (@20°C - see graph on page 2)	2.4	A
Nominal Clamping Voltage	120	V
Loop Resistance	<0.3	Ω

Line Side Gas Discharge Tube Specifications

Parameters	Value	Units
DC Spark-Over Voltage	150 ± 15%	V
Impulse Spark-Over Voltage (1KV/μS)	≤ 650	V
Surge Discharge Current (10/1000μS)	200	A
Surge Discharge Current (8/20μS)	20	kA
AC Discharge Current (50Hz)	20	A
Insulation Resistance	≥ 10	GΩ
Capacitance @ 1MHz	≤ 1.5	pF
Arc Voltage at 1A	~(15-25)	V

Internal Side Metal Oxide Varistor Specifications

Parameter	Value	Units
Varistor Clamping Voltage (1mA)	120 ± 10%	V
Clamping Voltage (@100A Peak)	200	V
Maximum Peak Current (8/20μS) – 1 Times	6	kA
Maximum Peak Current (8/20μS) – 2 Times	5	kA
Maximum Energy (10/1000 μS)	40	J
Typical Capacitance @ 1kHz	1700	pF

Self-Resting Fuse

This cassette contains the below rated self-resetting fuses. However due to their enclosed nature the cassette is derated according to the temperature curve below.

Parameter (Individual Components)	555275	Units
Maximum Voltage	72	Vdc
Hold Current (@20°C) See graph below.	3750	mA
Trip Current	7500	mA
Maximum Current	40	A

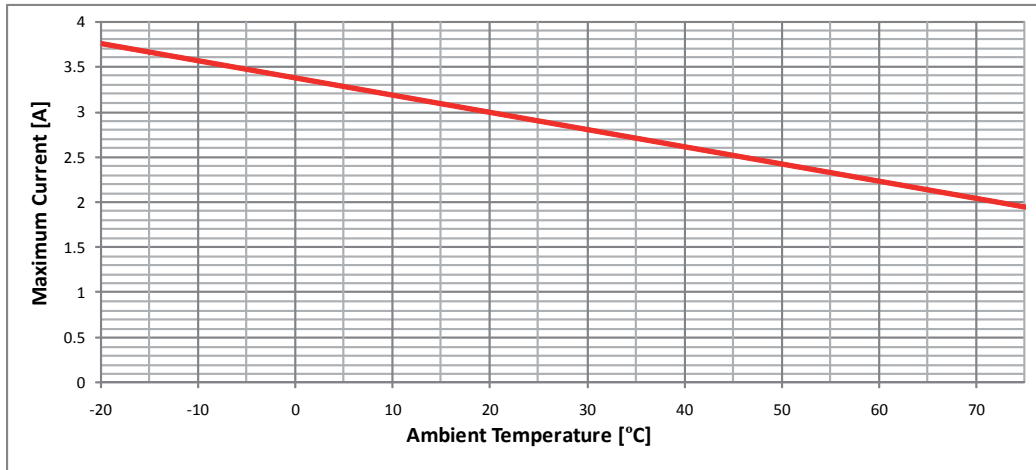

Temperature Derating Graph

*Please note the above graph is the average trip current and may vary up to ± 20%.

Mechanical & Environmental Specifications

Termination Module	Elsafe 216600A
Dimensions	62mm (D) x 110mm (L) x 24mm (W)
Operating Temperature	-20°C to + 75°C
Storage Temperature	-40°C to + 85°C
Relative Humidity	Up to 95%
Fire Rating	94 V0
Weight	100g
Housing Material	Polycarbonate

Approvals

Agency	Approval Number
Queensland Rail	C0092



elsafe

Version: OCT 2022

Elsafe, Unit 2, 11-17 Wilmette Place,
Mona Vale NSW 2103, Australia
Tel: 1300 357 233 Fax: +61 2 9454 7505
sales@oelsafe.com.au <https://railways.elsafe.com.au/>

OE House, Calder Park, Thomas Maddison Lane,
Durkar, Wakefield, WF4 3GH
Tel: +44 (0) 1924 367255 Fax: +44 (0) 1924 290652
sales@oelectrics.co.uk <https://oelectrics.co.uk/>



555375 - Transient Protection Cassettes

The 555375 Transient Protection Cassette is fitted with Gas Discharge Tubes (GDT) and Metal Oxide Varistors (MOV) protection between the inputs and also to earth. This cassette is a higher current version of the 555175/555275 as it features internal high current inductors. This cassette has a special DC rated GDT which will not have follow on current issues for supply voltages of less than 60V DC. Both MOVs are fused to further enhance the performance and safety of the cassette.

The Cassette features an indicator window which is normally green, indicating that it is fit for service. Should there ever be a transient that stresses the internal MOV beyond its safe rating the indicator window will turn red. This indicates that the Cassettes have been over stressed and **MUST** be replaced.

Electrical Specifications

Parameter	Value	Units
Rated Voltage	50	Vdc
Nominal Clamping Voltage	120	V
Current Rating	8	A
Loop Resistance	< 100	mΩ
Loop Inductance	66	uH

Line- Line Gas Discharge Tube Specifications

Parameter	Value	Units
DC Spark Over Voltage	1400±30%	V
DC Operating Voltage	60±20%	V
Surge Discharge Current (10/1000µS) (300 Operations)	100	A
Surge Discharge Current (8/20µS 5x (+) / 5x (-))	20	kA
Insulation Resistance	>10	GΩ
Capacitance (1MHz)	≤1	pF

Metal Oxide Varistor Specifications

Parameter	Value	Units
Varistor Voltage (1mA)	120±10%	V
Clamping Voltage (100A)	200	V
Maximum Peak Current (8/20µS) – 1 Times	6	kA
Maximum Peak Current (8/20µS) – 2 Times	5	kA
Maximum Energy (10/1000 µS)	40	J
Typical Capacitance @ 1kHz	1700	pF

Line-Earth Gas Discharge Tube Specifications

Parameter	Value	Units
DC Breakdown Voltage	150±20%	V
Impulse Breakdown Voltage (1kV/μs)	≤700	V
AC Discharge Current (50Hz)	20	A
Surge Discharge Current (10/1000μS)	100	A
Nominal Surge Discharge Current (8/20μS)	20	kA
Insulation Resistance	>10	GΩ
Capacitance (1MHz)	≤20	pF
Arc Voltage at 1A	~25	V

Window Labels

according to the images below

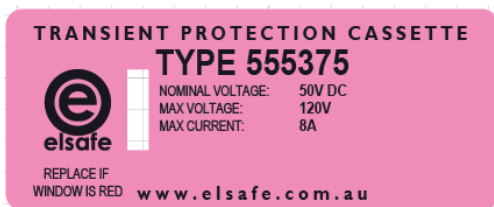

Mechanical & Environmental Specifications

Termination Module	Elsafe 216600A
Dimensions	62mm (D) x 110mm (L) x 24mm (W)
Operating Temperature	-20°C to + 75°C
Storage Temperature	-40°C to + 85°C
Relative Humidity	Up to 95%
Fire Rating	94 V0
Weight	100g
Housing Material	Polycarbonate

elsafe

Version: OCT 2022

Elsafe, Unit 2, 11-17 Wilmette Place,
Mona Vale NSW 2103, Australia
Tel: 1300 357 233 Fax: +61 2 9454 7505
sales@oeelsafe.com.au <https://railways.elsafe.com.au/>

OE House, Calder Park, Thomas Maddison Lane,
Durkar, Wakefield, WF4 3GH
Tel: +44 (0) 1924 367255 Fax: +44 (0) 1924 290652
sales@oeelectrics.co.uk <https://oeelectrics.co.uk/>



555620 – Filter & Transient Protection Cassettes

The 555620 cassettes provide filtering and transient protection for high-voltage AC circuits. The circuit consists of an inductor-capacitor filter, with additional Y capacitors to Earth, for common and differential mode filtering. A Metal Oxide Varistor (MOV) is fitted between live and neutral to minimise the let through voltage. The MOV is in series with a 10A thermal fuse which limits the current during an over voltage event.

A LED shows the status of the cassette and during normal operation it should glow green. If the LED no longer glows this indicates that the cassette has been overstressed and MUST be replaced.

Electrical Specifications

Parameter	555620	Units
Rated Working Voltage	110	V ac
Current Rating	15	A
Attenuation @ 50KHz	25	dB
Attenuation @ 10MHz	80	dB

Metal Oxide Varistor Specifications

Parameter	555620	Units
Varistor Clamping Voltage (1mA)	240 ± 10%	V
Clamping Voltage (@ 300A peak)	395	V
Max Peak Current (8/20 us) – 1 time	6.5	kA
Max Peak Current (8/20 us) – 2 times	5.0	kA
Maximum Energy (10/1000 us)	84	J
Maximum Energy (2mS)	60	J
Typical Capacitance @ 1kHz	830	pF

Mechanical & Environmental Specifications

Termination Module	Elsafe 216600A
Dimensions	62mm (D) x 110mm (L) x 24mm (W)
Operating Temperature	-20°C to + 75°C
Storage Temperature	-40°C to + 85°C
Relative Humidity	Up to 95%
Fire Rating	94 V0
Weight	90g
Housing Material	Polycarbonate

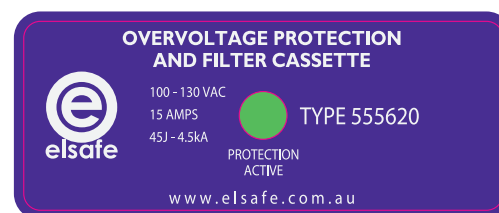

555630 – Filter & Transient Protection Cassettes

The 555630 cassettes provide filtering and transient protection for high-voltage AC circuits. The circuit consists of an inductor-capacitor filter, with additional Y capacitors to Earth, for common and differential mode filtering. A Metal Oxide Varistor (MOV) is fitted between live and neutral to minimise the let through voltage. The MOV is in series with a 10A thermal fuse which limits the current during an over voltage event.

A LED shows the status of the cassette and during normal operation it should glow green. If the LED no longer glows this indicates that the cassette has been overstressed and MUST be replaced.

Electrical Specifications

Parameter	555630	Units
Rated Working Voltage	240	V ac
Current Rating	15	A
Attenuation @ 50KHz	25	dB
Attenuation @ 10MHz	80	dB

Metal Oxide Varistor Specifications

Parameter	555630	Units
Varistor Clamping Voltage (1mA)	430 ± 10%	V
Clamping Voltage (@ 100A peak)	710	V
Max Peak Current (8/20 us) – 1 time	6.5	kA
Max Peak Current (8/20 us) – 2 times	5.0	kA
Maximum Energy (10/1000 us)	155	J
Maximum Energy (2mS)	110	J
Typical Capacitance @ 1kHz	460	pF

Mechanical & Environmental Specifications

Termination Module	Elsafe 216600A
Dimensions	62mm (D) x 110mm (L) x 24mm (W)
Operating Temperature	-20°C to + 75°C
Storage Temperature	-40°C to + 85°C
Relative Humidity	Up to 95%
Fire Rating	94 V0
Weight	90g
Housing Material	Polycarbonate

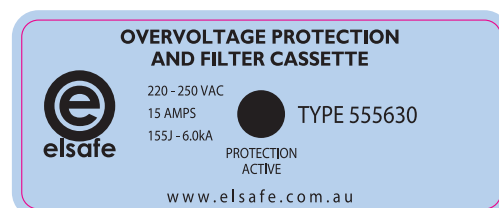

557010 - Track Diode

The 557010 Track Diode is intended for use in Railway signalling systems where AC/DC track circuits are used. It protects the connected equipment from overvoltage events that arise from lightning strikes or fault currents.

The Track Diode comprises of two 50W Zener diodes connected together implementing dual redundancy. The equipment is resin-encapsulated within a cylindrical, fully-sealed, weatherproof and UV-stabilized housing, fitted with 2 x 3 meter 10mm² lengths of connecting wire.

Electrical Specifications

Parameter	Value	Units
Zener Voltage (at 1700mA)	7.5 ± 5%	V dc
Zener Current Maximum	5900	mA
Forward Voltage V F (@ I F = 10A)	1.5	V MAX
Max Reverse Current @5V	125	uA

Typical AC/DC Track Circuit Application:

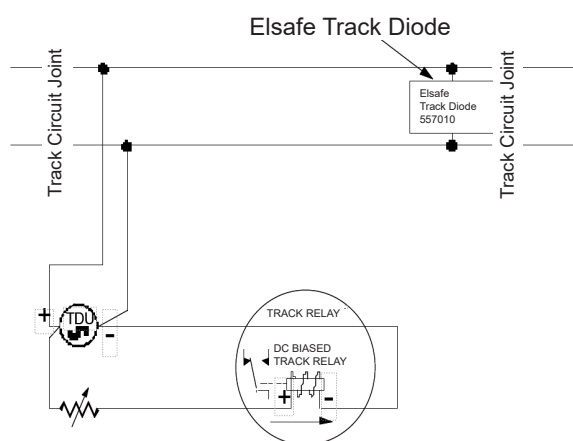

Mechanical & Environmental Specifications

Dimensions	76.5mm (max diameter) x 104mm (length)
Operating Temperature (PVC softening point)	-20°C to + 80°C
UV Stabilisation	Yes
Fire Rating	Will not support Combustion (AS 1530)
Weight	1400g
Housing Material	Polyvinyl Chloride (PVC)

Approvals

Agency	Approval Number
Queensland Rail	C0050A

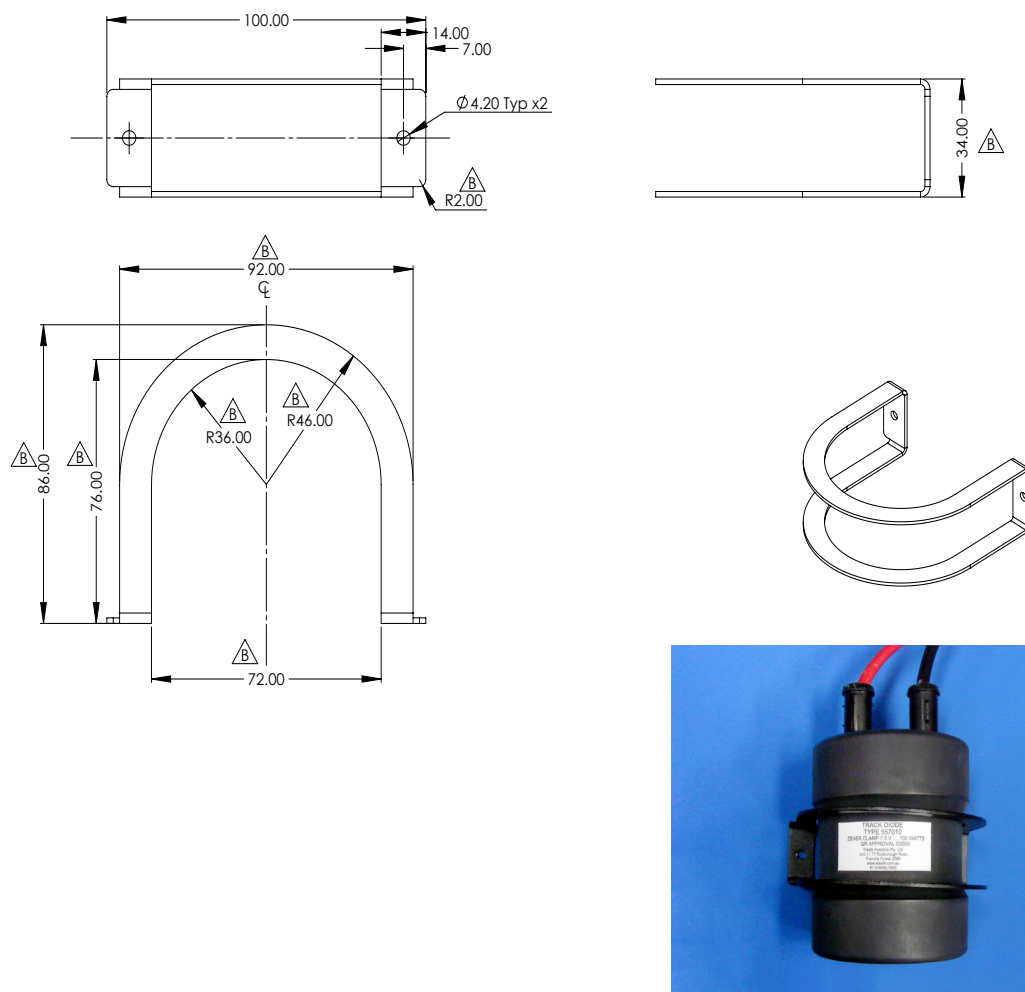

RESIN INFORMATION

Material	Polyurethane Resin
Properties	UV, ageing and weather resistant, Excellent adherence to Polymeric Cables SVHC and Halogen free contains no hazardous substances
Rated Temperature	-25°C to 120°C
Dielectric Strength	38kV/mm

557012 - Track Diode

The 557012 Track Diode is intended for use in railway signalling systems where AC/DC track circuits are used. It protects the connected equipment from overvoltage events that arise from lightning strikes or fault currents.

The Track Diode comprises of two 50W Zener diodes connected together, implementing dual redundancy. The equipment is resin-encapsulated within a sealed rectangular box for internally housed use, fitted with 2 x 1 meter 10mm² lengths of connecting wire.

Electrical Specifications

Parameter	Value	Units
Zener Voltage (at 1700mA)	7.5 ± 5%	V dc
Zener Current Maximum	5900	mA
Forward Voltage V F (@ I F = 10A)	1.5	V MAX
Max Reverse Current @5V	125	uA

Typical AC/DC Track Circuit Application:

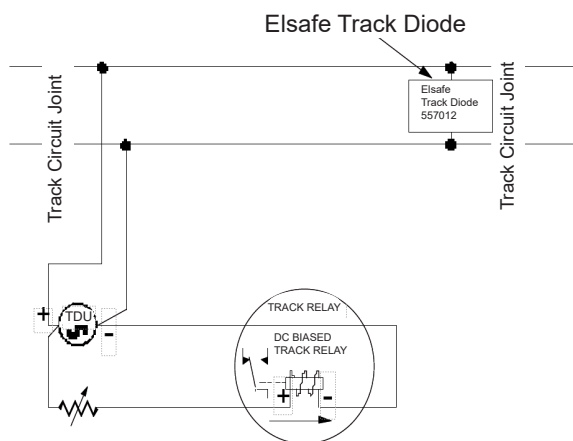

Mechanical & Environmental Specifications

Housing Dimensions (Housing)	40mm (H) x 60mm (W) x 110mm (L)
Operating Temperature	-20°C to + 80°C
UV Stabilisation	No, Housed Use Only
Fire Rating	UL94-VO
Weight	1400g (TBC)
Housing Material	ABS

Approvals

Agency	Approval Number
Queensland Rail	C0050A

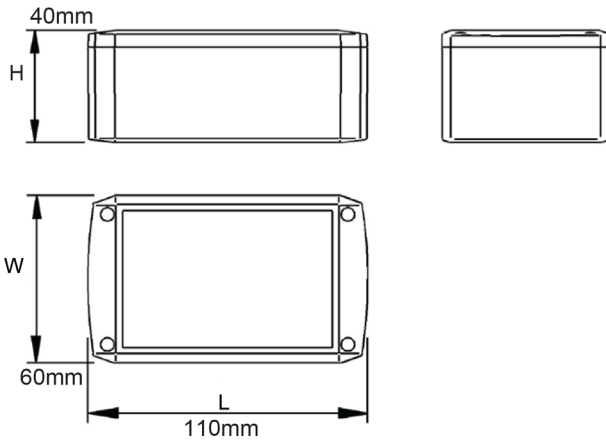

Resin Information

Material	Polyurethane Resin
Properties	UV, ageing and weather resistant, Excellent adherence to Polymeric Cables SVHC and Halogen free contains no hazardous substances
Rated Temperature	-25°C to 120°C
Dielectric Strength	38kV/mm

555715 – Transient Protection Cassette

The 555715 Transient protection Cassette features three Gas Discharge Tubes (GDTs) and an additional Metal Oxide Varistor (MOV) for faster response and increased surge capability, connected Live–Neutral, Live–Earth and Neutral–Earth.

Electrical Specifications

Parameters	Value	Units
Rated Clamping Voltage	90	V
Maximum Current – Series Connection	30	A
Maximum Current – Shunt Connection	200	A
Loop Resistance	<6	mΩ

Gas Discharge Tube Specifications

Parameters	Value	Units
DC Spark – Over Voltage	90 ± 20%	V
Impulse Spark – Over Voltage (1KV/μS)	<700	V
Nominal Impulse Discharge Current (8/20μS)	60	kA
Single Impulse Discharge Current (8/20μS)	80	kA
Nominal AC Discharge Current	60	A
AC Discharge Current (50Hz, 9 Cycles)	100	A
Insulation Resistance (250V dc)	>10	GΩ
Capacitance (1MHz)	<20	pF
Arc Voltage at 1A	~25	V

Metal Oxide Varistor Specifications

Parameter	Value	Units
Varistor Clamping Voltage	240 ± 10%	V
Clamping Voltage (@300A Peak)	395	V
Maximum Peak Current (8/20μS) – 1 Times	6.5	kA
Maximum Peak Current (8/20μS) – 2 Times	5.0	kA
Maximum Energy (10/1000 μS)	84	J
Typical Capacitance @ 1kHz	830	pF

Mechanical & Environmental Specifications

Termination Module	Elsafe 216600A
Dimensions	62mm (D) x 110mm (L) x 24mm (W)
Operating Temperature	-20°C to + 75°C
Storage Temperature	-40°C to + 85°C
Relative Humidity	Up to 95%
Fire Rating	94 V0
Weight	100g
Housing Material	Polycarbonate

Approvals

Agency	Approval Number
PTA OF WA	PRS38
ARTC	08-08-10-077

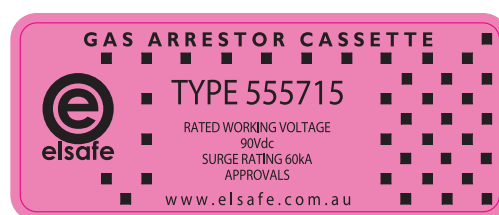

555716 – Transient Protection Cassette

The 555716 Transient protection Cassette features three 60kA Gas Discharge Tubes (GDTs) connected Live–Neutral, Live–Earth and Neutral–Earth for high surge capability. This cassette also features an additional Metal Oxide Varistor (MOV) Connected Live–Neutral (L2–L1) for faster response and lower let through voltage. These surge protection components are in series with a 35A fuse that activates the indicator window.

The Cassettes feature an indicator window which is normally green, indicating that it is fit for service. Should there ever be a transient that causes the internal current or temperature fuse to activate the indicator window flag will turn red. This

Electrical Specifications

Parameters	Value	Units
Rated Clamping Voltage	90	V
Maximum Current – Series Connection	30	A
Maximum Current – Shunt Connection	200	A
Loop Resistance	<6	mΩ

Gas Discharge Tube Specifications

Parameters	Value	Units
DC Spark – Over Voltage	90 ± 20%	V
Impulse Spark – Over Voltage (1KV/μS)	<700	V
Nominal Impulse Discharge Current (8/20μS)	60	kA
Single Impulse Discharge Current (8/20μS)	80	kA
Nominal AC Discharge Current	60	A
AC Discharge Current (50Hz, 9 Cycles)	100	A
Insulation Resistance (250V dc)	>10	GΩ
Capacitance (1MHz)	<20	pF
Arc Voltage at 1A	~25	V

Metal Oxide Varistor Specifications

Parameter	Value	Units
Varistor Clamping Voltage	240 ± 10%	V
Clamping Voltage (@300A Peak)	395	V
Maximum Peak Current (8/20μS) – 1 Times	6.5	kA
Maximum Peak Current (8/20μS) – 2 Times	5.0	kA
Maximum Energy (10/1000 μS)	84	J
Typical Capacitance @ 1kHz	830	pF

Mechanical & Environmental Specifications

Termination Module	Elsafe 216600A
Dimensions	62mm (D) x 110mm (L) x 24mm (W)
Operating Temperature	-20°C to + 75°C
Storage Temperature	-40°C to + 85°C
Relative Humidity	Up to 95%
Fire Rating	94 V0
Weight	100g
Housing Material	Polycarbonate

Approvals

Agency	Approval Number
ARTC	ARTC 08-08-10-077a

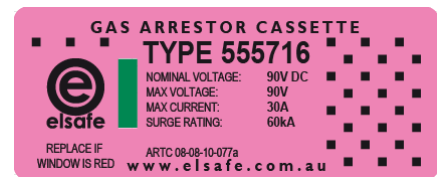

555718 – Transient Protection Cassette

The 555718 Transient protection Cassette features three Gas Discharge Tubes (GDTs) and an additional Metal Oxide Varistor (MOV) for faster response and increased surge capability, connected Live–Neutral, Live–Earth and Neutral–Earth.

Electrical Specifications

Parameters	Value	Units
Rated Clamping Voltage	150	V
Maximum Current – Series Connection	30	A
Maximum Current – Shunt Connection	200	A
Loop Resistance	<6	mΩ

Gas Discharge Tube Specifications

Parameters	Value	Units
DC Spark – Over Voltage	150± 20%	V
Impulse Spark – Over Voltage (1KV/μS)	<700	V
Nominal Impulse Discharge Current (8/20μS)	60	kA
Single Impulse Discharge Current (8/20μS)	80	kA
Nominal Alternating Discharge Current	60	A
Alternating Discharge Current (50Hz, 9 Cycles)	100	A
Insulation Resistance (250V dc)	>10	GΩ
Capacitance (1MHz)	<20	pF
Arc Voltage at 1A	~25	V

Metal Oxide Varistor Specifications

Parameter	Value	Units
Varistor Clamping Voltage	180 ± 10%	V
Clamping Voltage (@300A Peak)	300	V
Maximum Peak Current (8/20μS) – 1 Times	6.5	kA
Maximum Peak Current (8/20μS) – 2 Times	5.0	kA
Maximum Energy (10/1000 μS)	60	J
Typical Capacitance @ 1kHz	1100	pF

Mechanical & Environmental Specifications

Termination Module	Elsafe 216600A
Dimensions	62mm (D) x 110mm (L) x 24mm (W)
Operating Temperature	-20°C to + 75°C
Storage Temperature	-40°C to + 85°C
Relative Humidity	Up to 95%
Fire Rating	94 V0
Weight	100g
Housing Material	Polycarbonate

Approvals

Agency	Approval Number
PTA OF WA	PRS38



555720 - Transient Protection Cassette

The 555720 Transient Protection Cassette features three Gas Discharge Tubes (GDTs), connected Live-Neutral, Live-Earth and Neutral-Earth.

Electrical Specifications

Parameter	Value	Units
Rated Clamping Voltage	230	V
Maximum Current – Series Connection	30	A
Maximum Current – Shunt Connection	200	A
Loop Resistance	<6	mΩ

Gas Discharge Tube Specifications

Parameter	Value	Units
DC Spark – Over Voltage	230 ± 20%	V
Impulse Spark – Over Voltage (1KV/μS)	<800	V
Nominal Impulse Discharge Current (8/20μS)	60	kA
Single Impulse Discharge Current (8/20μS)	80	kA
Nominal AC Discharge Current	60	A
AC Discharge Current (50Hz, 9 Cycles)	100	A
Insulation Resistance (250V dc)	>10	GΩ
Capacitance (1MHz)	<20	pF
Arc Voltage at 1A	~25	V

Mechanical & Environmental Specifications

Termination Module	Elsafe 216600A
Dimensions	62mm (D) x 110mm (L) x 24mm (W)
Operating Temperature	-20°C to + 75°C
Storage Temperature	-40°C to + 85°C
Relative Humidity	Up to 95%
Fire Rating	94 V0
Weight	100g
Housing Material	Polycarbonate

Approvals

Agency	Approval Number
Queensland Rail	C0051
PTA of WA	PRS37
ARTC	08-08-10-077

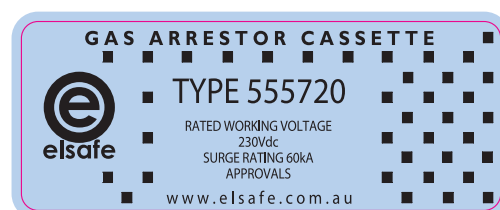

555725 - Transient Protection Cassette

The 555725 Transient Protection Cassette features three Gas Discharge Tubes (GDTs), connected Live-Neutral, Live-Earth and Neutral-Earth. These GDTs are in series with a 35A fuse that activates the indicator window

The Cassettes feature an indicator window which is normally green, indicating that it is fit for service. Should there ever be a transient that stresses the Cassettes beyond their safe rating the indicator window will turn red. This indicates that the GDT have been overstressed, and the Cassette **MUST** be replaced.

Electrical Specifications

Parameter	Value	Units
Rated Clamping Voltage	230	V
Maximum Current – Series Connection	30	A
Maximum Current – Shunt Connection	200	A
Loop Resistance	<6	mΩ

Gas Discharge Tube Specifications

Parameter	Value	Units
DC Spark – Over Voltage	230 ± 20%	V
Impulse Spark – Over Voltage (1KV/μS)	<800	V
Nominal Impulse Discharge Current (8/20μS)	60	kA
Single Impulse Discharge Current (8/20μS)	80	kA
Nominal AC Discharge Current	60	A
AC Discharge Current (50Hz, 9 Cycles)	100	A
Insulation Resistance (250V dc)	>10	GΩ
Capacitance (1MHz)	<20	pF
Arc Voltage at 1A	~25	V

Mechanical & Environmental Specifications

Termination Module	Elsafe 216600A
Dimensions	62mm (D) x 110mm (L) x 24mm (W)
Operating Temperature	-20°C to + 75°C
Storage Temperature	-40°C to + 85°C
Relative Humidity	Up to 95%
Fire Rating	94 V0
Weight	100g
Housing Material	Polycarbonate

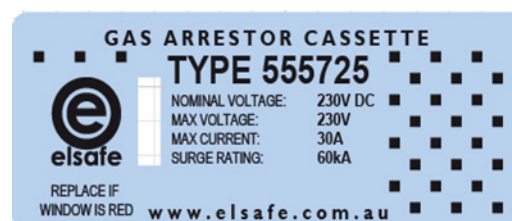

555730 – Transient Protection Cassette

The 555730 Transient Protection Cassette features three Gas Discharge Tubes (GDTs), connected Live-Neutral, Live-Earth and Neutral-Earth.

Electrical Specifications

Parameter	Value	Units
Rated Clamping Voltage	350	V
Maximum Current – Series Connection	30	A
Maximum Current – Shunt Connection	200	A
Loop Resistance	<6	mΩ

Gas Discharge Tube Specifications

Parameter	Value	Units
DC Spark-Over Voltage	350 ± 20%	V
Impulse Spark-Over Voltage (1KV/μS)	<800	V
Nominal Impulse Discharge Current (8/20μs)	60	kA
Single Impulse Discharge Current (8/20μs)	80	kA
Nominal AC Discharge Current	60	A
AC Discharge Current (50Hz, 9 Cycles)	100	A
Insulation Resistance (250V dc)	>10	GΩ
Capacitance (1MHz)	<20	pF
Arc Voltage at 1A	~25	V

Mechanical & Environmental Specifications

Termination Module	Elsafe 216600A
Dimensions	62mm (D) x 110mm (L) x 24mm (W)
Operating Temperature	-20°C to + 75°C
Storage Temperature	-40°C to + 85°C
Relative Humidity	Up to 95%
Fire Rating	94 V0
Weight	100g
Housing Material	Polycarbonate

Approvals

Agency	Approval Number
Queensland Rail	C0051

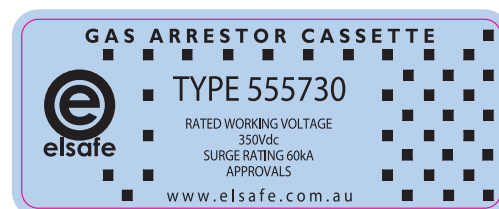

555905 - ISDN Protection Cassette

The Elsafe 555905 technical cassette is specifically designed for the protection of ISDN circuitry, designed for Queensland Rail to their requirements. The cassette features two MOV components to EARTH, and through link busbars.

Electrical Specification

Parameter	Value	Units
Nominal Rated Working Voltage	895	V DC
Maximum Voltage	1100	V
Maximum Current	30	A

Internal-Side Metal Oxide Varistor Specifications

Parameter	Value	Units
Varistor Voltage (1mA)	1100±10%	V
Maximum Applied Voltage (AC _{rms})	680	V _{rms}
Maximum Applied Voltage (DC)	895	V
Clamping Voltage (50A)	1815	V
Capacitance	180	pF
Energy (2ms)	140	J
Peak Current (8/20µs)	4.5	kA

Mechanical & Environmental Specifications

Termination Module	Elsafe 216600A
Dimensions	62mm (D) x 110mm (L) x 24mm (W)
Operating Temperature	-20°C to + 75°C
Storage Temperature	-40°C to + 85°C
Relative Humidity	Up to 95%
Fire Rating	94 V0
Weight	100g
Housing Material	Polycarbonate

Window Labels

according to the images below



557010– Track Diode

The 557010 Track Diode is intended for use in Railway signalling systems where AC/DC track circuits are used. It protects the connected equipment from overvoltage events that arise from lightning strikes or fault currents.

The Track Diode comprises of two 50W Zener diodes connected together implementing dual redundancy. The equipment is silicone-encapsulated within a cylindrical, fully-sealed, weatherproof and UV-stabilized housing, fitted with 2 x 3 meter 10mm² lengths of connecting wire.

Electrical Specifications

Parameter	Value	Units
Zener Voltage	7.5 ± 5%	V dc
Zener Current Maximum	5900	mA
Forward Voltage V_F (@ $I_F = 10A$)	1.5	V MAX

Typical AC/DC Track Circuit Application:

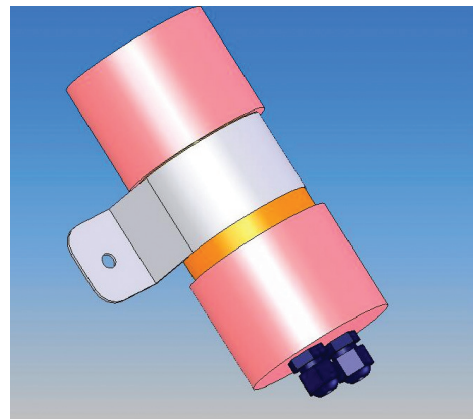
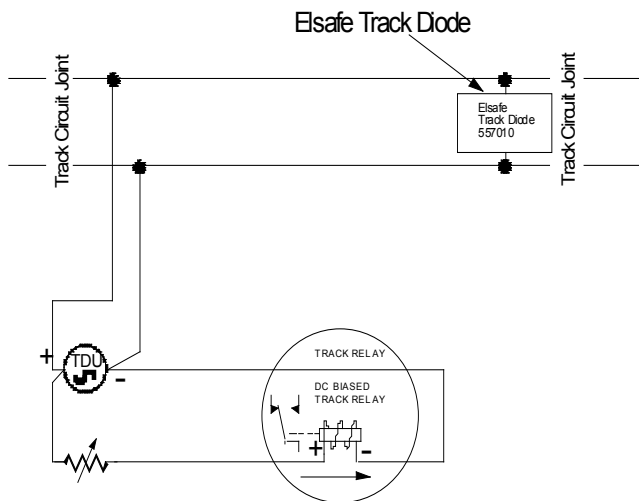

Mechanical & Environmental Specifications

Dimensions	65mm Diameter x 120mm
Operating Temperature	-20°C to +75°C
Storage Temperature	-40°C to +85°C
Relative Humidity	Up to 95%
Fire Rating	94 V0
Weight	650g
Housing Material	Polycarbonate

Approvals

Agency	Approval Number
Queensland Rail	C 0050

557025 – Voltage Equaliser / Arrestor System

The 557025 Voltage Equaliser/Arrestor System is designed to protect signalling equipment by suppressing transients at the point of entry to particular installations. The system comprises of 2 modules, 557020 Equalising Arrestor Module and 557022 Installation Module.

557020 Equalising Arrestor Module, has a number of protective devices, two high-capacity Gas Discharge Tube (GDT)s are connected in series between the Internal signal 'L' and Common 'C' conductors. These GDTs are designed to fail to a short circuit if they are exposed to excessive heat due to extended over-voltages. The 2 signal Lines 'L' are separated by a series connected 6A HRC fuse. Two Metal Oxide Varistors (MOVs) are inserted between Internal and Earth conductors 'L&E' and between Common and Earth conductors 'C&E'. The common and line conductors are brought out to colour-coded 4mm sockets that allow testing and monitoring.

557022 Installation Module, comprises of 4 Wago cage terminals each with a 4mm socket for the mating of the Equalising Arrestor Module. The plug and socket layout is polarised to prevent misconnection to the Arrestor module. The wago clamps terminals are identified by labels fitted to the locking clips on the Arrestor Module. The incoming cables connect to the terminals marked 'External' and the protected equipment connect to the terminals marked 'Internal'.

See Legend:

C	Common Conductor (Passes straight through)
L	Signal Conductor (Interrupted)
E	Earth Conductor (External side only)
X	Not connected

Electrical Specifications

Parameter	Common (C) - Signal (L)	Common (C)/Signal(S) - Earth (E)	Units
Nominal Clamping Voltage	140	430	V
Surge Current Rating	80	26	kA
Rated Current	6		A
Maximum Cable Size	16	16	mm ²

Individual Metal Oxide Varistor Specifications

Parameter	Value	Units
Varistor Clamping Voltage (1mA)	430 ± 10%	V
Clamping Voltage (@ 300A peak)	710	V
Max Peak Current (8/20 us) – 1 time	6.5	kA
Max Peak Current (8/20 us) – 2 times	5.0	kA
Maximum Energy (10/1000 us)	155	J
Typical Capacitance @ 1kHz	460	pF

Individual Gas Discharge Tube Specifications

Parameter	Value	Units
DC Spark-Over Voltage	70 ± 20%	V
Impulse Spark-Over Voltage (1KV/μS)	600	V
Nominal Impulse Discharge Current (8/20μs)	80	kA
Single Impulse Discharge Current (8/20μs)	100	kA
Nominal AC Discharge Current	80	A
AC Discharge Current (50Hz)	100	A
Insulation Resistance (250V dc)	10	GΩ
Capacitance (1MHz)	20	pF
Arc Voltage at 1A	~25	V

Mechanical & Environmental Specifications

Dimensions (Fully Assembled)	72mm(H) x 95mm(W) x 135mm(D)
Operating Temperature	-20°C to + 75°C
Storage Temperature	-40°C to + 85°C
Relative Humidity	Up to 95%
Fire Rating	94 V0
Weight	390g
Housing Material	Polycarbonate



Approvals

Agency	Approval Number
Queensland Rail	C 0057

557022 Terminals

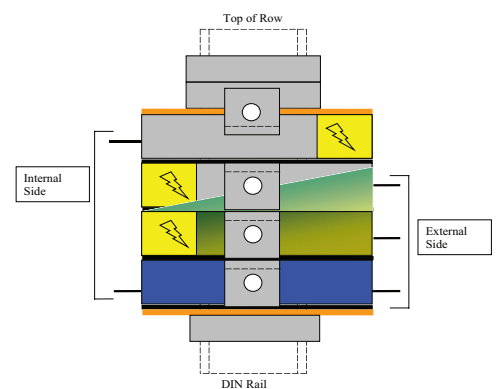

elsafe

Version: OCT 2022

Elsafe, Unit 2, 11-17 Wilmette Place,
Mona Vale NSW 2103, Australia
Tel: 1300 357 233 Fax: +61 2 9454 7505
sales@oeelsafe.com.au <https://railways.elsafe.com.au/>

OE House, Calder Park, Thomas Maddison Lane,
Durkar, Wakefield, WF4 3GH
Tel: +44 (0) 1924 367255 Fax: +44 (0) 1924 290652
sales@oeelectrics.co.uk <https://oeelectrics.co.uk/>



557028 – Voltage Equaliser / Arrestor System

The 557028 Voltage Equaliser/Arrestor System is designed to protect signalling equipment by suppressing transients at the point of entry to particular installations. The system comprises of 2 modules, 557020 Equalising Arrestor Module and 557023 Installation Module.

557020 Equalising Arrestor Module, has a number of protective devices, two high-capacity Gas Discharge Tube (GDT)s are connected in series between the Internal signal 'L' and Common 'C' conductors. These GDTs are designed to fail to a short circuit if they are exposed to excessive heat due to extended over-voltages. The 2 signal Lines 'L' are separated by a series connected 6A HRC fuse. Two Metal Oxide Varistors (MOVs) are inserted between Internal and Earth conductors 'L&E' and between Common and Earth conductors 'C&E'. The common and line conductors are brought out to colour-coded 4mm sockets that allow testing and monitoring.

557023 Installation Module, comprises of 4 Wago cage terminals each with a 4mm socket for the mating of the Equalising Arrestor Module. The plug and socket layout is polarised to prevent misconnection to the Arrestor module. The wago clamps terminals are identified by labels fitted to the locking clips on the Arrestor Module. The incoming cables connect to the terminals marked 'External' and the protected equipment connect to the terminals marked 'Internal'. This base differs from 557022 in that EARTH is not connected to the DIN RAIL.

See Legend:

C	Common Conductor (Passes straight through)
L	Signal Conductor (Interrupted)
E	Earth Conductor (External side only) Not Connected to DIN RAIL
X	Not connected

Electrical Specifications

Parameter	Common (C) - Signal (L)	Common (C)/Signal(S) - Earth (E)	Units
Nominal Clamping Voltage	140	430	V
Surge Current Rating	80	26	kA
Rated Current	6		A
Maximum Cable Size	16	16	mm ²

Individual Metal Oxide Varistor Specifications

Parameter	Value	Units
Varistor Clamping Voltage (1mA)	430 ± 10%	V
Clamping Voltage (@ 300A peak)	710	V
Max Peak Current (8/20 us) – 1 time	6.5	kA
Max Peak Current (8/20 us) – 2 times	5.0	kA
Maximum Energy (10/1000 us)	155	J
Typical Capacitance @ 1kHz	460	pF

Individual Gas Discharge Tube Specifications

Parameter	Value	Units
DC Spark-Over Voltage	70 ± 20%	V
Impulse Spark-Over Voltage (1KV/μS)	600	V
Nominal Impulse Discharge Current (8/20μs)	80	kA
Single Impulse Discharge Current (8/20μs)	100	kA
Nominal AC Discharge Current	80	A
AC Discharge Current (50Hz)	100	A
Insulation Resistance (250V dc)	10	GΩ
Capacitance (1MHz)	20	pF
Arc Voltage at 1A	~25	V

Mechanical & Environmental Specifications

Dimensions (Fully Assembled)	72mm(H) x 95mm(W) x 135mm(D)
Operating Temperature	-20°C to + 75°C
Storage Temperature	-40°C to + 85°C
Relative Humidity	Up to 95%
Fire Rating	94 V0
Weight	390g
Housing Material	Polycarbonate

Installation Module
557023

+

Equalising Arrestor
Module 557020

=

Assembled System
557028

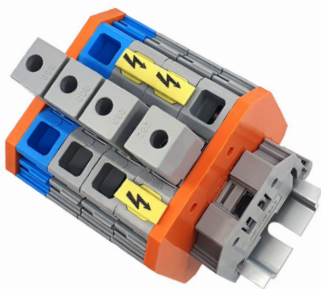

557023 Terminals

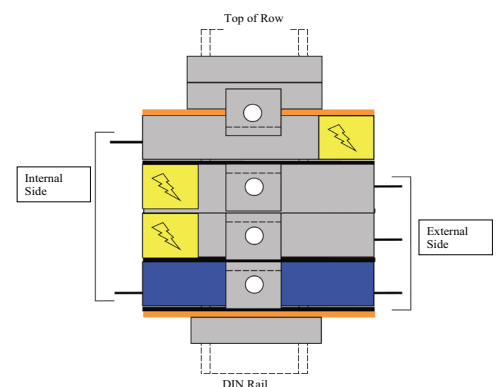

Approvals

Agency	Approval Number

elsafe

Elsafe, Unit 2, 11-17 Wilmette Place,
Mona Vale NSW 2103, Australia
Tel: 1300 357 233 Fax: +61 2 9454 7505
sales@oelsafe.com.au <https://railways.elsafe.com.au/>

OE House, Calder Park, Thomas Maddison Lane,
Durkar, Wakefield, WF4 3GH
Tel: +44 (0) 1924 367255 Fax: +44 (0) 1924 290652
sales@oelectrics.co.uk <https://oelectrics.co.uk/>

Version: OCT 2022

